

Internet Technologies - Quick Reference Guide

Internet

- Internet is a world-wide global system of interconnected computer networks.
- Internet uses the standard Internet Protocol *TCP/IP*.
- Every computer in internet is identified by a unique IP address.
- IP Address is a unique set of numbers *such as* 110.22.33.114 which identifies a computer location.
- A special computer DNS *Domain Name Server* is used to give name to the IP Address so that user can locate a computer by a name.
- For example, a DNS server will resolve a name **http://www.gmail.com** to a particular IP address to uniquely identify the computer on which this website is hosted.
- Internet is accessible to every user all over the world.

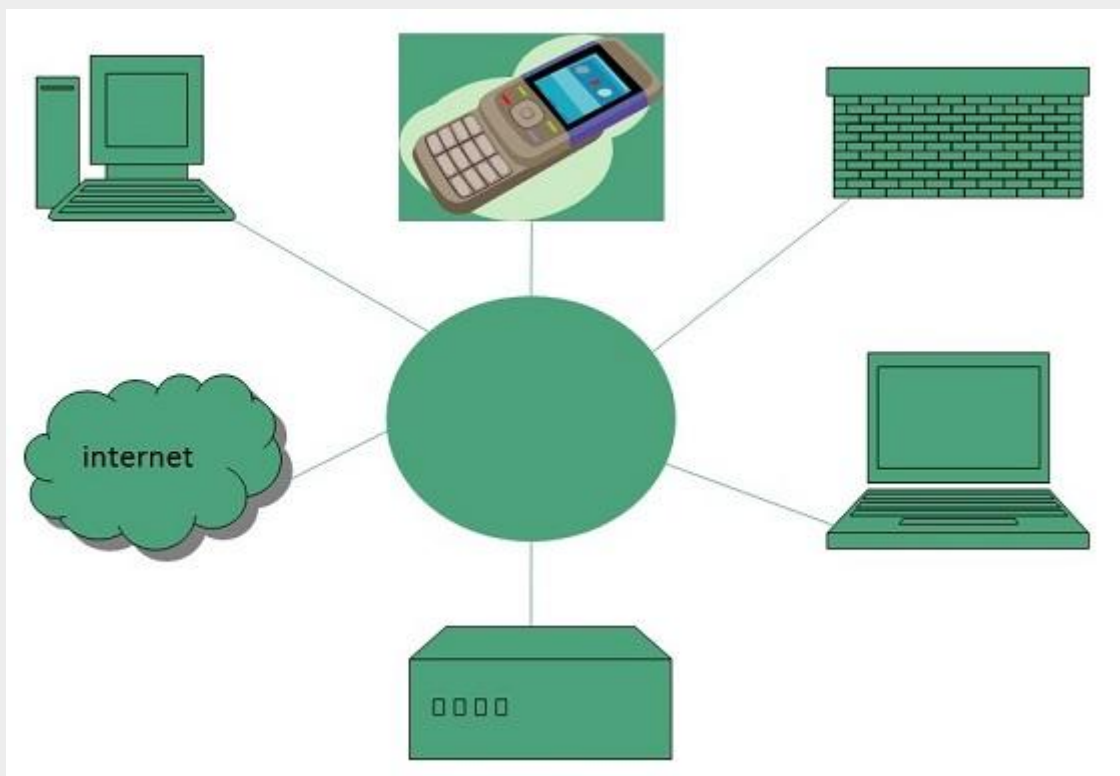

Internet Evolution

The concept of Internet was originated in 1969 and has undergone several technological & Infrastructural changes as discussed below:

- The origin of Internet devised from the concept of **Advanced Research Project Agency Network ARPANET**.
- **ARPANET** was developed by United States Department of Defense.
- Basic purpose of ARPANET was to provide communication among the various bodies of government.
- Initially, there were only four nodes, formally called **Hosts**.
- In 1972, the **ARPANET** spread over the globe with 23 nodes located at different countries and thus became known as **Internet**.
- By the time, with invention of new technologies such as TCP/IP protocols, DNS, WWW, browsers, scripting languages etc., Internet provided a medium to publish and access information over the web.

Internet Advantages

Internet covers almost every aspect of life, one can think of. Here, we will discuss some of the advantages of Internet:

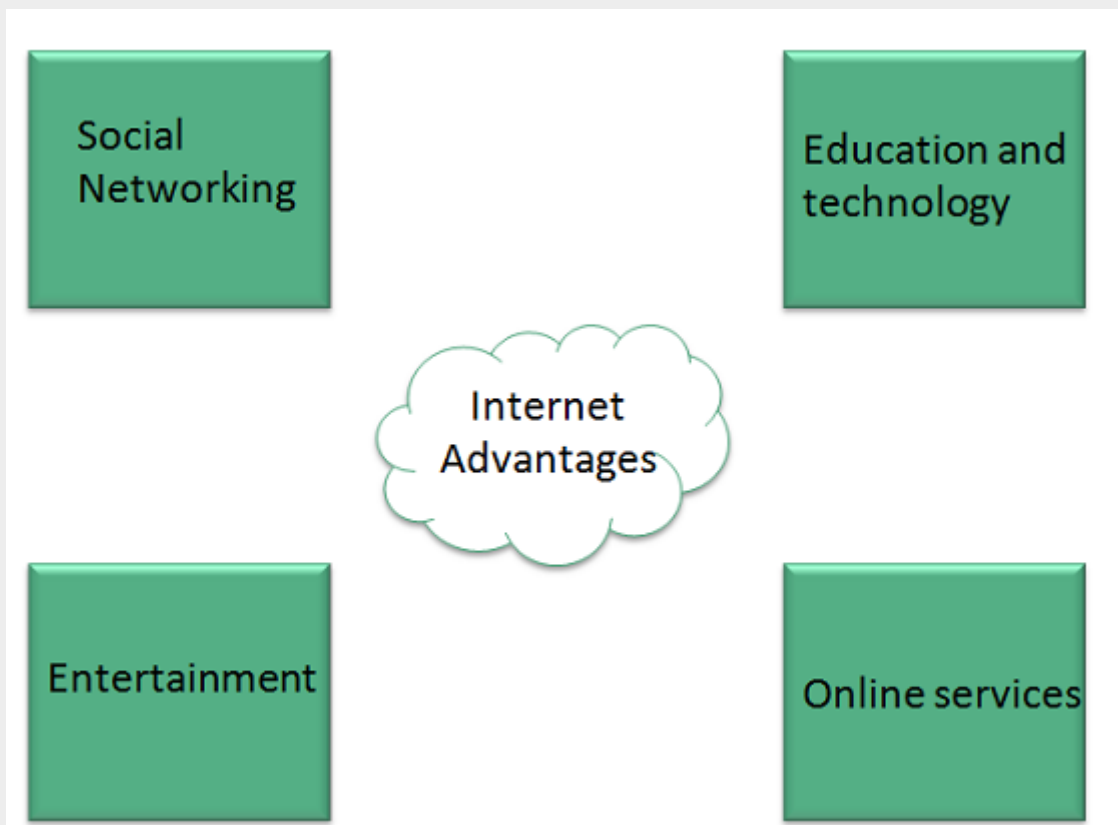

Internet Disadvantages

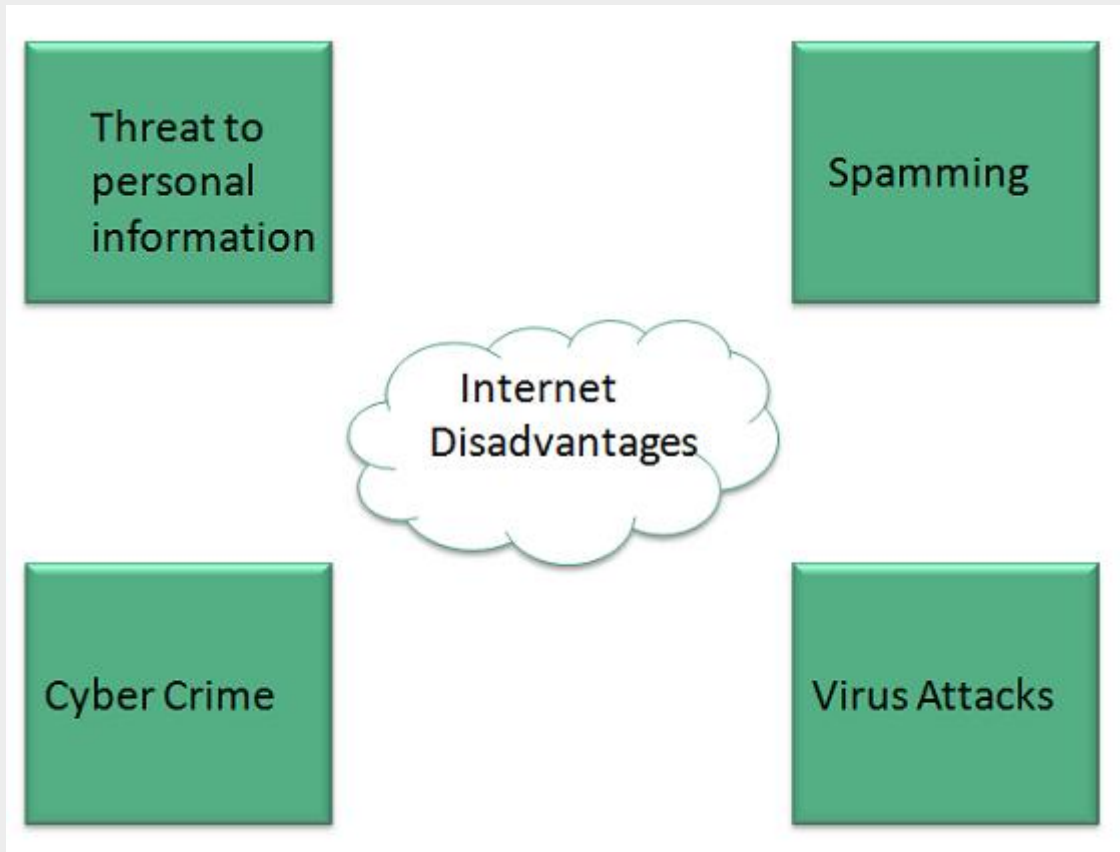

Intranet

Intranet is defined as private network of computers within an organization with its own server and firewall. Moreover we can define Intranet as:

- Intranet is system in which multiple PCs are networked to be connected to each other. PCs in intranet are not available to the world outside of the intranet.
- Usually each company or organization has their own Intranet network and members/employees of that company can access the computers in their intranet.
- Every computer in internet is identified by a unique IP address.
- Each computer in Intranet is also identified by a IP Address, which is unique among the computers in that Intranet.

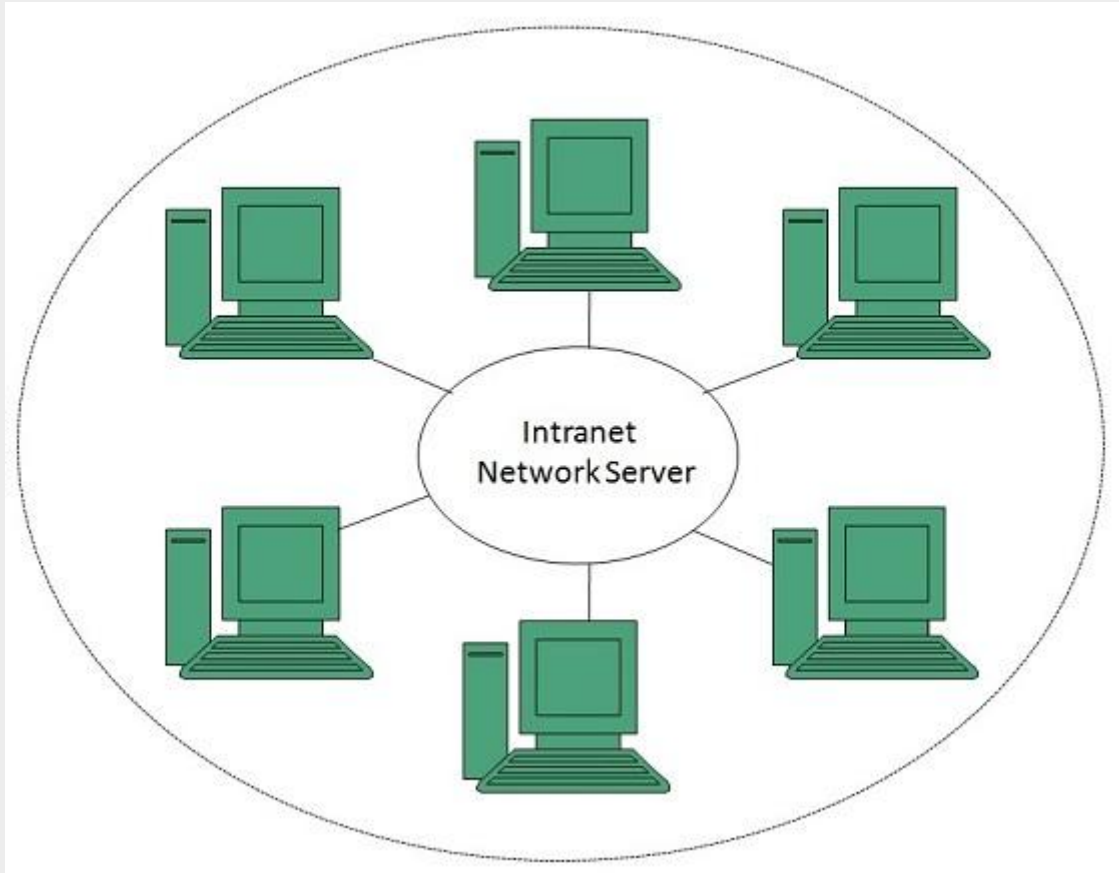

Benefits

Intranet is very efficient and reliable network system for any organization. It is beneficial in every aspect such as collaboration, cost-effectiveness, security, productivity and much more.

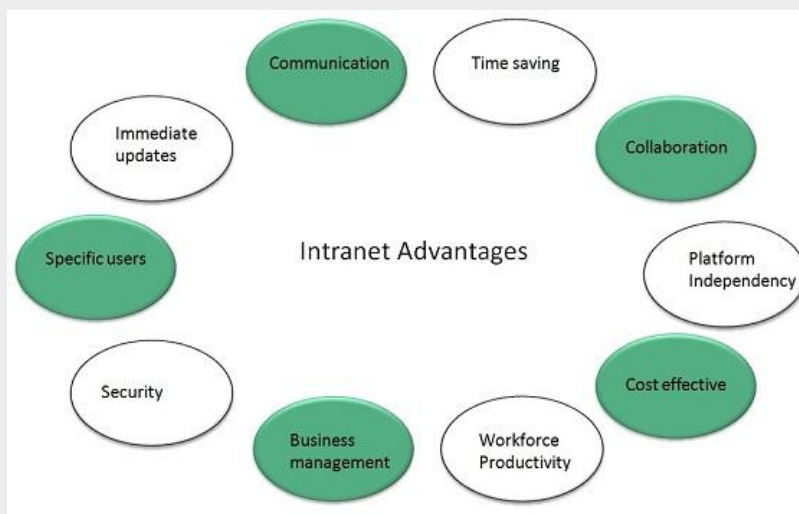

Communication

Intranet offers easy and cheap communication within an organization. Employees can communicate using chat, e-mail or blogs.

Time Saving

Information on Intranet is shared in real time.

Collaboration

Information is distributed among the employees as according to requirement and it can be accessed by the authorized users, resulting in enhanced teamwork.

Platform Independency

Intranet can connect computers and other devices with different architecture.

Cost Effective

Employees can see the data and other documents using browser rather than printing them and distributing duplicate copies among the employees, which certainly decreases the cost.

Workforce Productivity

Data is available at every time and can be accessed using company workstation. This helps the employees work faster.

Business Management

It is also possible to deploy applications that support business operations.

Security

Since information shared on intranet can only be accessed within an organization, therefore there is almost no chance of being theft.

Specific Users

Intranet targets only specific users within an organization therefore, once can exactly know whom he is interacting.

Immediate Updates

Any changes made to information are reflected immediately to all the users.

Issues

Apart from several benefits of Intranet, there also exist some issues.. These issues are shown in the following diagram:

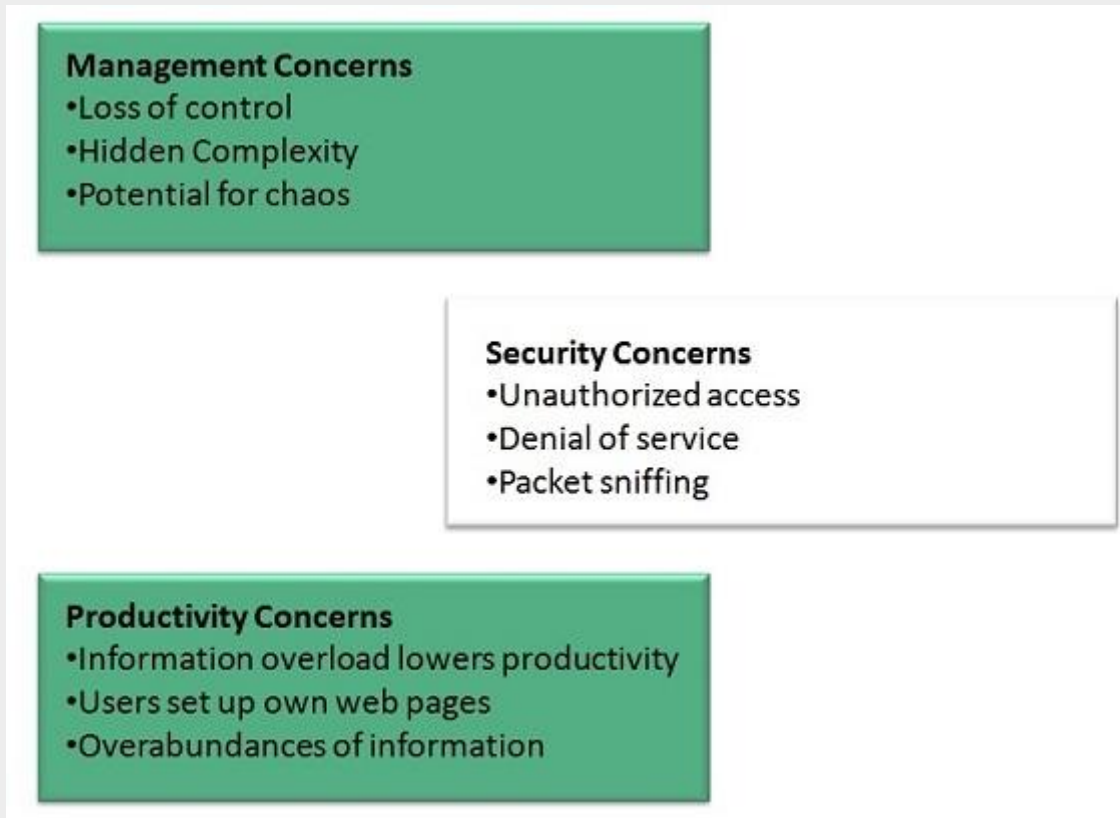

Applications

Intranet applications are same as that of Internet applications. Intranet applications are also accessed through a web browser. The only difference is that, Intranet applications reside on local server while Internet applications reside on remote server. Here, we've discussed some of these applications:

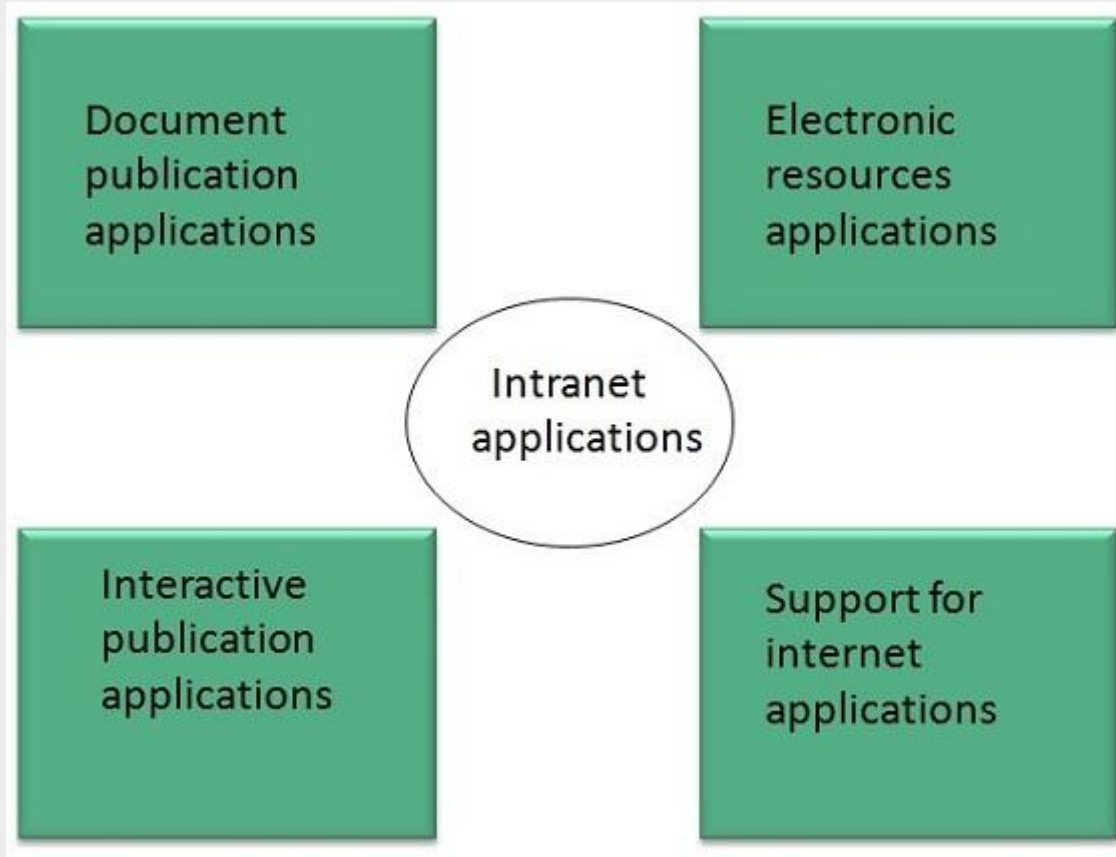

Document publication applications

Document publication applications allow publishing documents such as manuals, software guide, employee profits etc without use of paper.

Electronic resources applications

It offers electronic resources such as software applications, templates and tools, to be shared across the network.

Interactive Communication applications

Like on internet, we have e-mail and chat like applications for Intranet, hence offering an interactive communication among employees.

Support for Internet Applications

Intranet offers an environment to deploy and test applications before placing them on Internet.

Internet vs. Intranet

Apart from similarities there are some differences between the two. Following are the differences between Internet and Intranet:

Intranet	Internet
Localized Network.	Worldwide Network
Doesn't have access to Internet	Have access to Internet.
More Expensive	Less Expensive
More Safe	Less Safe
More Reliability	Less Reliability

Extranet

Extranet refers to network within an organization, using internet to connect to the outsiders in controlled manner. It helps to connect businesses with their customers and suppliers and therefore allows working in a collaborative manner.

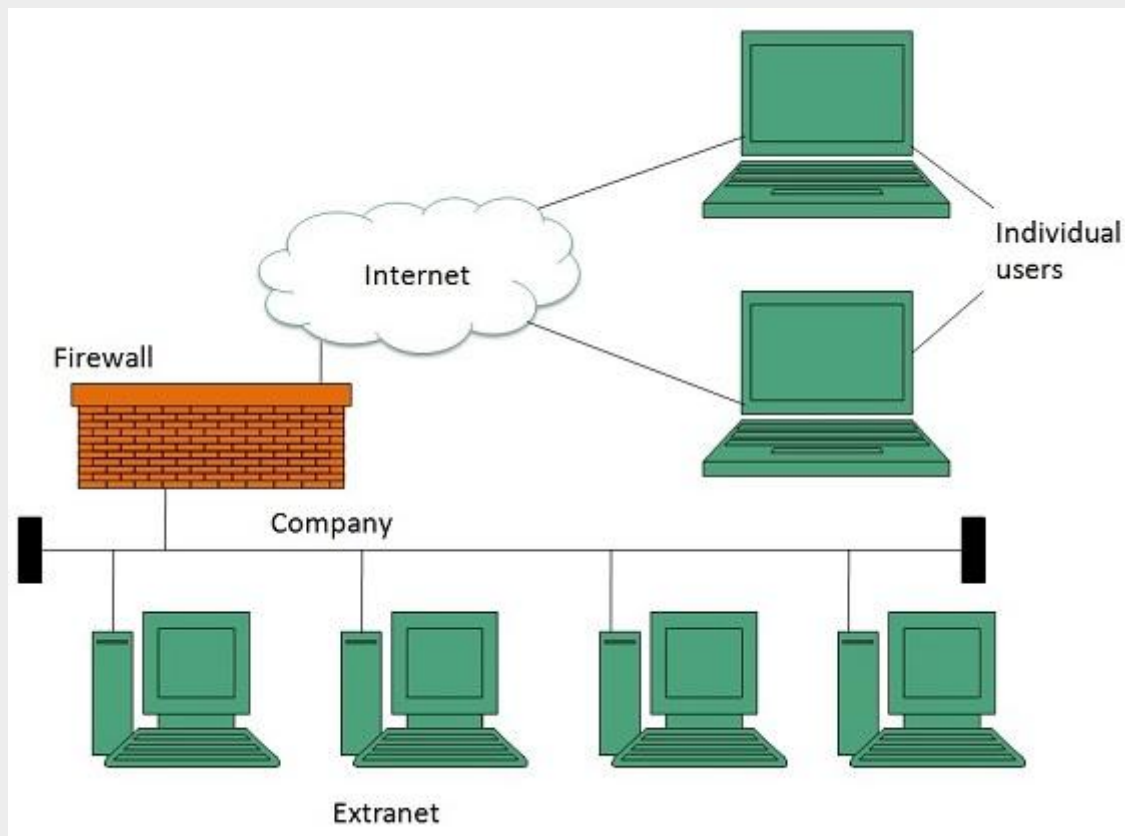

Extranet Benefits

Extranet proves to be a successful model for all kind of businesses whether small or big. Here are some of the advantages of extranet for employees, suppliers, business partners, and customers:

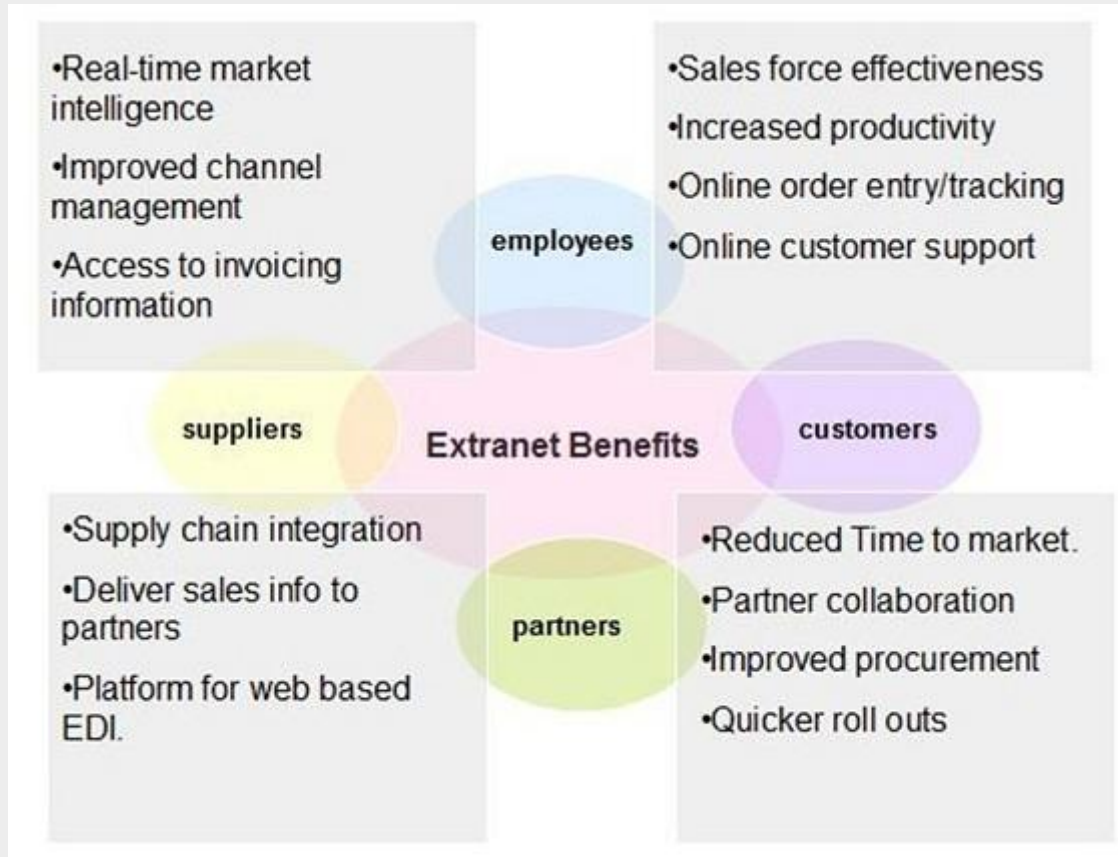

Extranet Issues

Apart for advantages there are also some issues associated with extranet. These issues are discussed below:

Hosting

Where the extranet pages will be held i.e. who will host the extranet pages. In this context there are two choices:

- Host it on your own server.
- Host it with an Internet Service Provider *ISP* in the same way as web pages.

But hosting extranet pages on your own server requires high bandwidth internet connection which is very costly.

Security

Additional firewall security is required if you host extranet pages on your own server which result in a complex security mechanism and increase work load.

Accessing Issues

Information can not be accessed without internet connection. However, information can be accessed in Intranet without internet connection.

Decreased Interaction

It decreases the face to face interaction in the business which results in lack of communication among customers, business partners and suppliers.

Extranet vs. Intranet

The following table shows differences between Extranet and Intranet:

Extranet	Intranet
Internal network that can be accessed externally.	Internal network that can not be accessed externally.
Extranet is extension of company's Intranet.	Only limited users of a company.
For limited external communication between customers, suppliers and business partners.	Only for communication within a company.

Internet Reference Models

OSI Reference Model

OSI is acronym of **Open System Interface**. This model is developed by the **International organization of Standardization ISO** and therefore also referred as **ISO-OSI** Model.

The OSI model consists of seven layers as shown in the following diagram. Each layer has a specific function, however each layer provide services to the layer above.

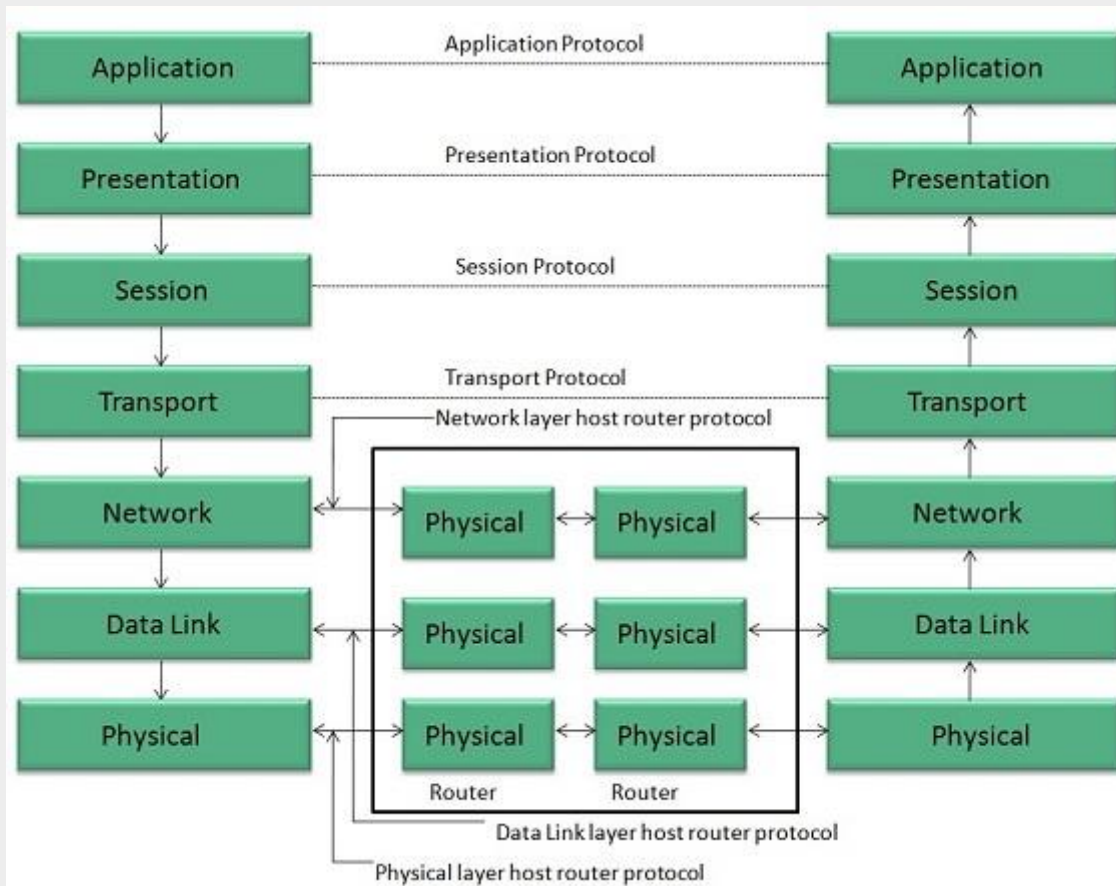

Physical Layer

The Physical layer is responsible for the following activities:

- Activating, maintaining and deactivating the physical connection.
- Defining voltages and data rates needed for transmission.
- Converting digital bits into electrical signal.
- Deciding whether the connection is simplex, half duplex or full duplex.

Data Link Layer

The data link layer performs the following functions:

- Performs synchronization and error control for the information which is to be transmitted over the physical link.
- Enables error detection, and adds error detection bits to the data which are to be transmitted.

Network Layer

Following are the functions of Network Layer:

- To route the signals through various channels to the other end.
- To act as the network controller by deciding which route data should take.
- To divide the outgoing messages into packets and to assemble incoming packets into messages for higher levels.

Transport Layer

The Transport layer performs the following functions:

- It decides if the data transmission should take place on parallel paths or single path.
- It performs multiplexing, splitting on the data.
- It breaks the data groups into smaller units so that they are handled more efficiently by the network layer.

The Transport Layer guarantees transmission of data from one end to other end.

Session Layer

The Session layer performs the following functions:

- Manages the messages and synchronizes conversations between two different applications.
- It controls logging on and off, user identification, billing and session management.

Presentation Layer

The Presentation layer performs the following functions:

<="" ul="">

- This layer makes it sure that the information is delivered in such a form that the receiving system will understand and use it.

Application Layer

The Application layer performs the following functions:

- It provides different services such as manipulation of information in several ways, retransferring the files of information, distributing the results etc.
- The functions such as LOGIN or password checking are also performed by the application layer.

TCP/IP Reference Model

TCP/IP model is practical model and is used in the Internet. TCP/IP is acronym of Transmission Control Protocol and Internet Protocol.

The **TCP/IP** model combines the two layers *Physical and Datalink layer* into one layer i.e. **Host-to-Network** layer. The following diagram shows the various layers of TCP/IP model:

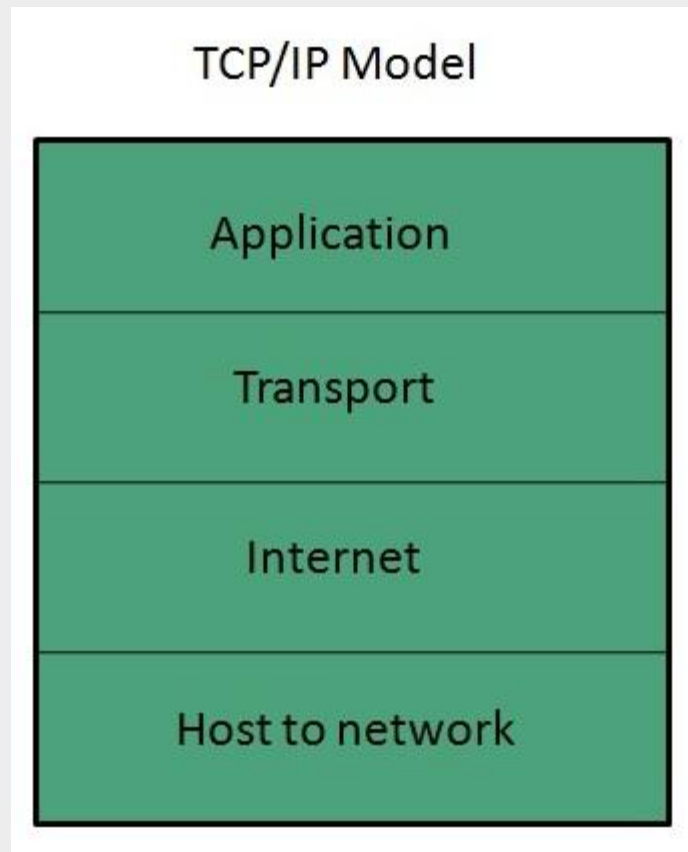

Application Layer

This layer is same as that of the OSI model and performs the following functions:

- It provides different services such as manipulation of information in several ways, retransferring the files of information, distributing the results etc.
- The functions such as LOGIN or password checking are also performed by the application layer.

Protocols used: TELNET, FTP, SMTP, DN, HTTP, NNTP are the protocols employed in this layer.

Transport Layer

It does the same functions as that of transport layer in OSI model. Here are the key points regarding transport layer:

- It uses **TCP** and **UDP** protocol for end to end transmission.
- TCP is reliable and **connection oriented protocol**.

- TCP also handles flow control.
- The UDP is not reliable and a **connection less protocol** also does not perform flow control.

Protocols used: TCP/IP and UDP protocols are employed in this layer.

Internet Layer

The function of this layer is to allow the host to insert packets into network and then make them travel independently to the destination. However, the order of receiving the packet can be different from the sequence they were sent.

Protocols used: Internet Protocol *IP* is employed in Internet layer.

Host-to-Network Layer

This is the lowest layer in TCP/IP model. The host has to connect to network using some protocol, so that it can send IP packets over it. This protocol varies from host to host and network to network.

Protocols used: ARPANET, SATNET, LAN, packet radio are the protocols which are used in this layer.

Domain Name System Architecture

The Domain name system comprises of **Domain Names, Domain Name Space, Name Server** that have been described below:

Domain Names

Domain Name is a symbolic string associated with an IP address. There are several domain names available; some of them are generic such as **com, edu, gov, net** etc, while some country level domain names such as **au, in, za, us** etc.

The following table shows the **Generic Top-Level Domain** names:

Domain Name	Meaning
Com	Commercial business
Edu	Education
Gov	U.S. government agency
Int	International entity
Mil	U.S. military
Net	Networking organization
Org	Non profit organization

The following table shows the **Country top-level** domain names:

Domain Name	Meaning
au	Australia
in	India
cl	Chile
fr	France
us	United States
za	South Africa
uk	United Kingdom
jp	Japan
es	Spain
de	Germany
ca	Canada
ee	Estonia
hk	Hong Kong

Domain Name Space

The domain name space refers a hierarchy in the internet naming structure. This hierarchy has multiple levels *from 0 to 127*, with a root at the top. The following diagram shows the domain name space hierarchy:

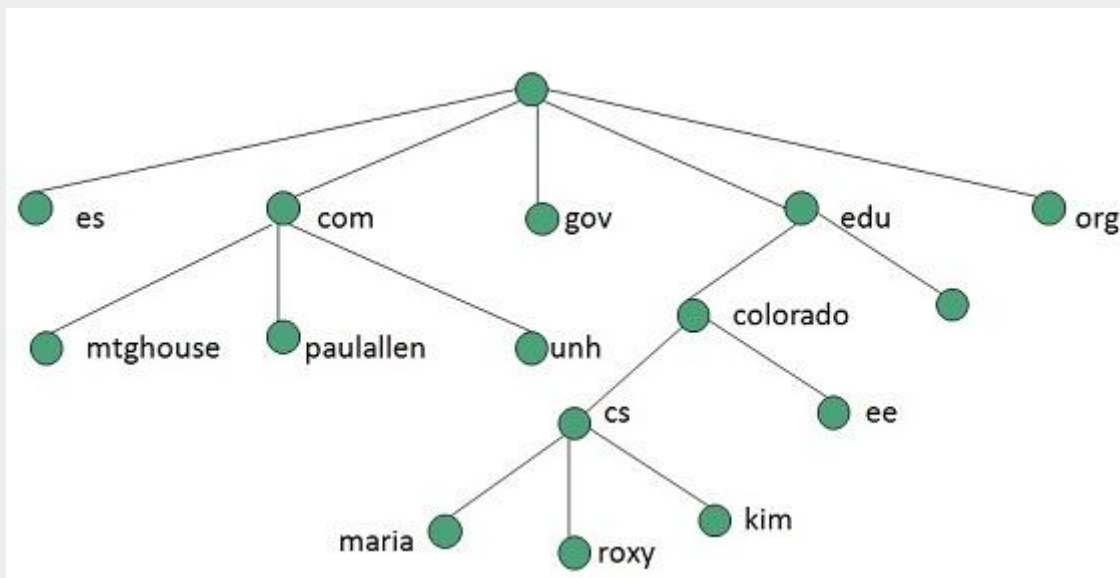

In the above diagram each subtree represents a domain. Each domain can be partitioned into sub domains and these can be further partitioned and so on.

Name Server

Name server contains the DNS database. This database comprises of various names and their corresponding IP addresses. Since it is not possible for a single server to maintain entire DNS database, therefore, the information is distributed among many DNS servers.

- Hierarchy of server is same as hierarchy of names.
- The entire name space is divided into the zones

Zones

Zone is collection of nodes *subdomains* under the main domain. The server maintains a database called zone file for every zone.

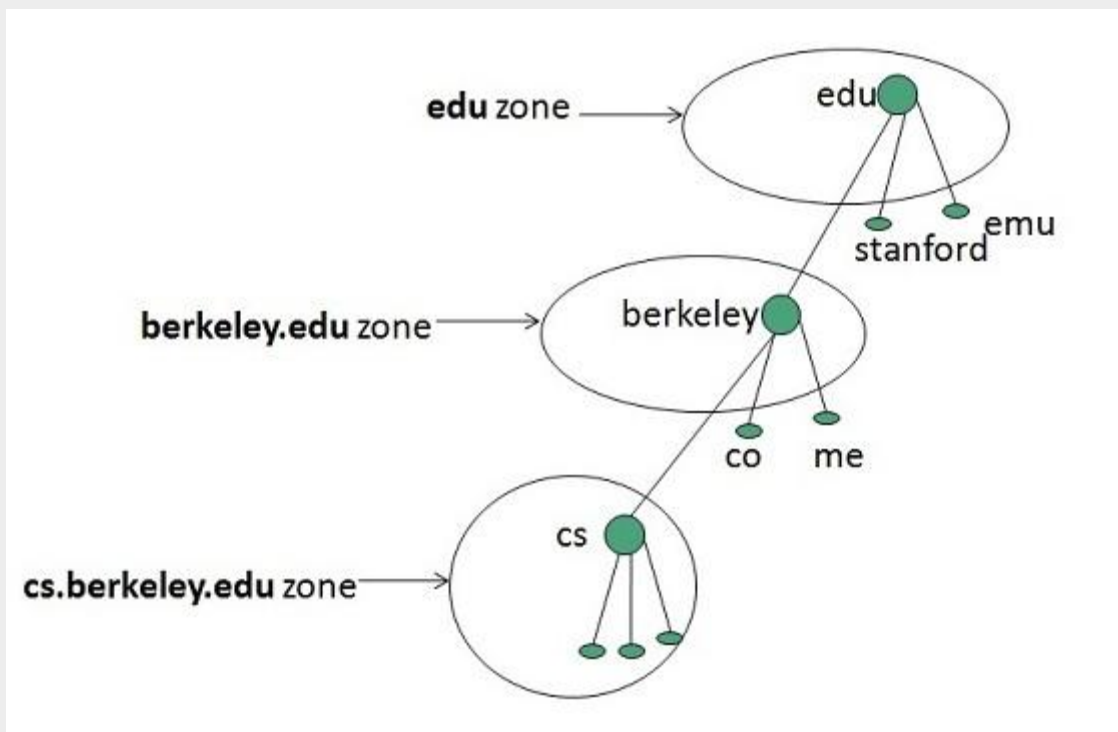

If the domain is not further divided into sub domains then domain and zone refers to the same thing.

The information about the nodes in the sub domain is stored in the servers at the lower levels however; the original server keeps reference to these lower levels of servers.

Types of Name Servers

Following are the three categories of Name Servers that manages the entire Domain Name System:

1. Root Server

2. Primary Server
3. Secondary Server

Root Server

Root Server is the top level server which consists of the entire DNS tree. It does not contain the information about domains but delegates the authority to the other server

Primary Servers

Primary Server stores a file about its zone. It has authority to create, maintain, and update the zone file.

Secondary Server

Secondary Server transfers complete information about a zone from another server which may be primary or secondary server. The secondary server does not have authority to create or update a zone file.

DNS Working

DNS translates the domain name into IP address automatically. Following steps will take you through the steps included in domain resolution process:

1. When we type **www.tutorialspoint.com** into the browser, it asks the local DNS Server for its IP address.

Here the local DNS is at ISP end.

2. When the local DNS does not find the IP address of requested domain name, it forwards the request to the root DNS server and again enquires about IP address of it.
3. The root DNS server replies with delegation that **I do not know the IP address of www.gmail.com but know the IP address of DNS Server.**
4. The local DNS server then asks the com DNS Server the same question.
5. The **com** DNS Server replies the same that it does not know the IP address of www.tutorialspont.com but knows the address of tutorialspoint.com.
6. Then the local DNS asks the tutorialspoint.com DNS server the same question.
7. Then tutorialspoint.com DNS server replies with IP address of www.tutorialspoint.com.
8. Now, the local DNS sends the IP address of www.tutorialspoint.com to the computer that sends the request.

Internet Services

Communication Services

There are various Communication Services available that offer exchange of information with individuals or groups. The following table gives a brief introduction to these services:

S.N.	Service Description
1	Electronic Mail Used to send electronic message over the internet.
2	Telnet Used to log on to a remote computer that is attached to internet.
3	Newsgroup Offers a forum for people to discuss topics of common interests.
4	Internet Relay Chat <i>IRC</i> Allows the people from all over the world to communicate in real time.
5	Mailing Lists Used to organize group of internet users to share common information through e-mail.
6	Internet Telephony <i>VoIP</i> Allows the internet users to talk across internet to any PC equipped to receive the call.
7	Instant Messaging Offers real time chat between individuals and group of people. Eg. Yahoo messenger, MSN messenger.

Information Retrieval Services

There exist several Information retrieval services offering easy access to information present on the internet. The following table gives a brief introduction to these services:

S.N.	Service Description
1	File Transfer Protocol <i>FTP</i> Enable the users to transfer files.
2	Archie It's updated database of public FTP sites and their content. It helps to search a file by its name.
3	Gopher Used to search, retrieve, and display documents on remote sites.
4	Very Easy Rodent Oriented Netwide Index to Computer Achieved <i>VERONICA</i> <i>VERONICA</i> is gopher based resource. It allows access to the information resource stored on gopher's servers.

Web Services

Web services allow exchange of information between applications on the web. Using web services, applications can easily interact with each other.

The web services are offered using concept of **Utility Computing**.

World Wide Web WWW

WWW is also known as W3. It offers a way to access documents spread over the several servers over the internet. These documents may contain texts, graphics, audio, video, hyperlinks. The hyperlinks allow the users to navigate between the documents.

Video Conferencing

Video conferencing or Video teleconferencing is a method of communicating by two-way video and audio transmission with help of telecommunication technologies.

Modes of Video Conferencing

Point-to-Point

This mode of conferencing connects two locations only.

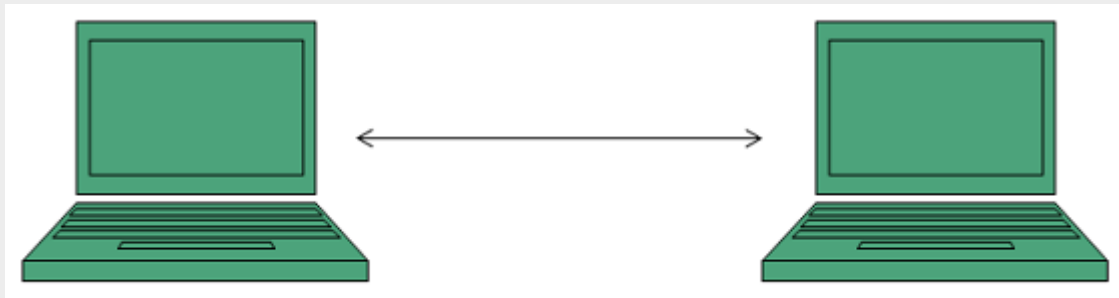

Multi-point

This mode of conferencing connects more than two locations through **Multi-point Control Unit MCU**.

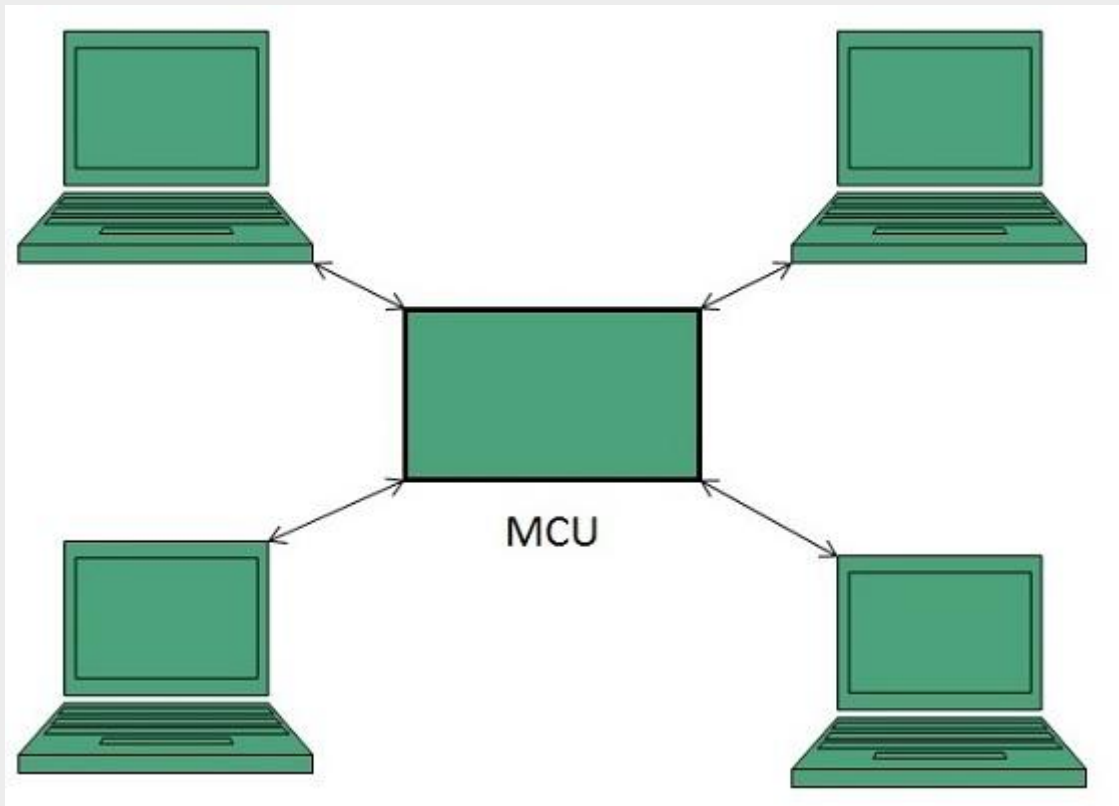

Internet Protocols

Transmission Control Protocol *TCP*

- Transmission Control Protocol *TCP* corresponds to the Transport Layer of OSI Model.
- *TCP* is a reliable and connection oriented protocol.
- *TCP* offers:
 - Stream Data Transfer.
 - Reliability.
 - Efficient Flow Control
 - Full-duplex operation.
 - Multiplexing.
- *TCP* offers connection oriented end-to-end packet delivery.
- *TCP* ensures reliability by sequencing bytes with a forwarding acknowledgement number that indicates to the destination the next byte the source expect to receive.
- It retransmits the bytes not acknowledged with in specified time period.

Internet Protocol *IP*

Internet Protocol is **connectionless** and **unreliable** protocol. It ensures no guarantee of successfully transmission of data.

In order to make it reliable, it must be paired with reliable protocol such as TCP at the transport layer.

Internet protocol transmits the data in form of a datagram as shown in the following diagram:

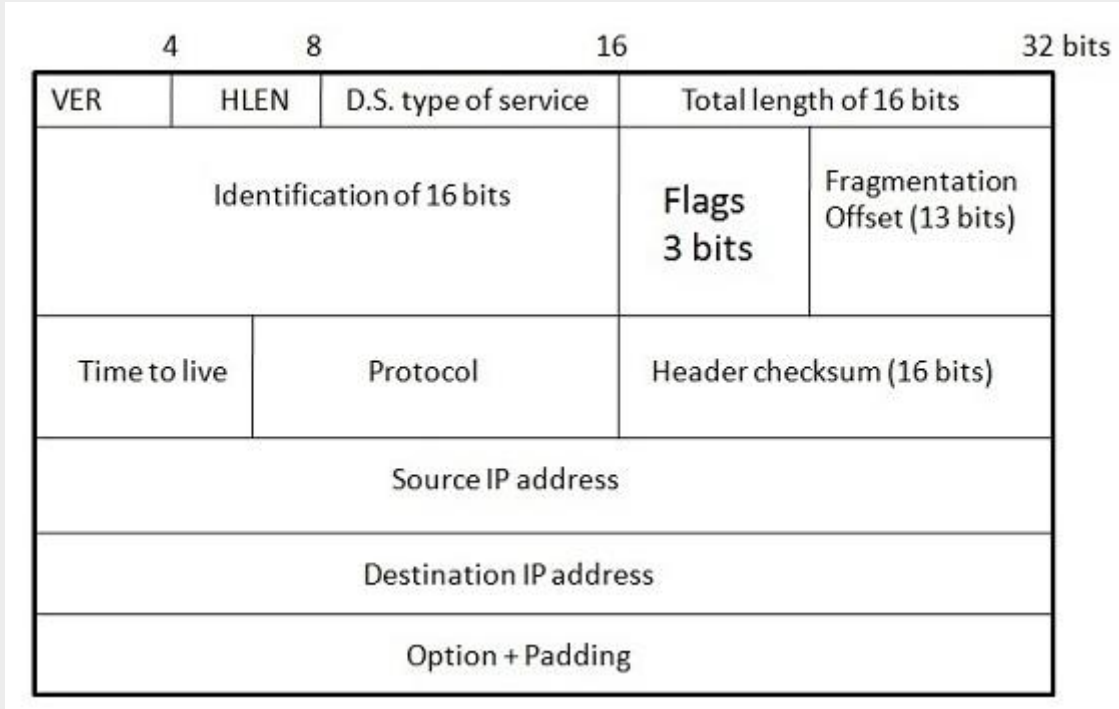

User Datagram Protocol *UDP*

Like IP, UDP is connectionless and unreliable protocol. It doesn't require making a connection with the host to exchange data. Since UDP is unreliable protocol, there is no mechanism for ensuring that data sent is received.

UDP transmits the data in form of a datagram. The UDP datagram consists of five parts as shown in the following diagram:

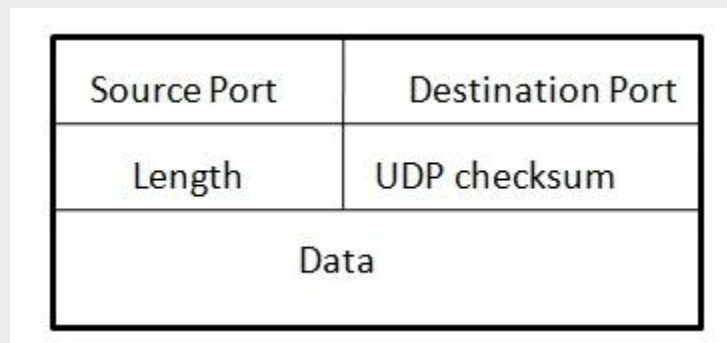

File Transfer Protocol *FTP*

FTP is used to copy files from one host to another. FTP offers the mechanism for the same in following manner:

- FTP creates two processes such as Control Process and Data Transfer Process at both ends i.e. at client as well as at server.
- FTP establishes two different connections: one is for data transfer and other is for control information.
- **Control connection** is made between **control processes** while **Data Connection** is made between <="" b="">
- FTP uses **port 21** for the control connection and **Port 20** for the data connection.

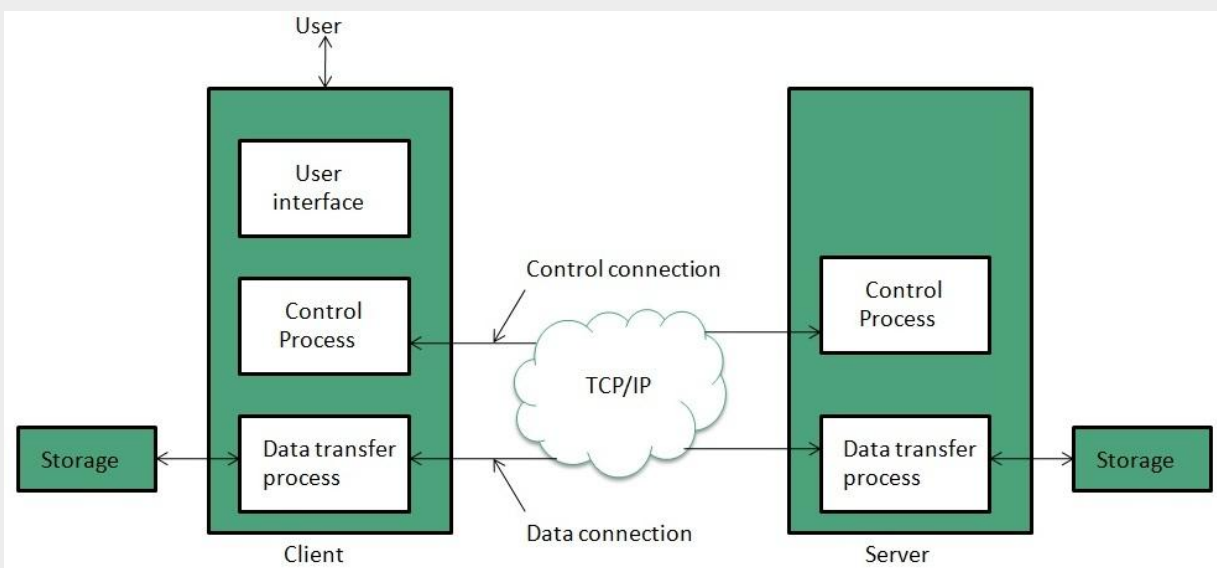

Trivial File Transfer Protocol *TFTP*

Trivial File Transfer Protocol is also used to transfer the files but it transfers the files without authentication. Unlike FTP, TFTP does not separate control and data information. Since there is no authentication exists, TFTP lacks in security features therefore it is not recommended to use TFTP.

Key points

- TFTP makes use of UDP for data transport. Each TFTP message is carried in separate UDP datagram.
- The first two bytes of a TFTP message specify the type of message.
- The TFTP session is initiated when a TFTP client sends a request to upload or download a file.
- The request is sent from an ephemeral UDP port to the **UDP port 69** of an TFTP server.

Telnet

Telnet is a protocol used to log in to remote computer on the internet. There are a number of Telnet clients having user friendly user interface. The following diagram shows a person is logged in to computer A, and from there, he remote logged into computer B.

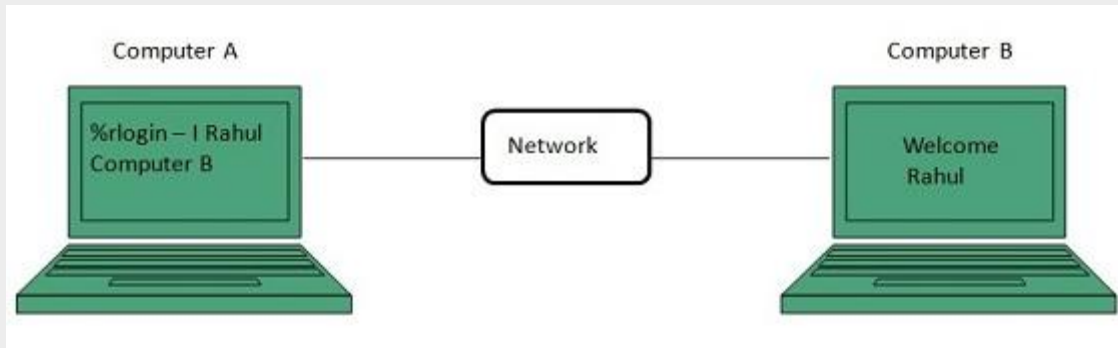

Hyper Text Transfer Protocol *HTTP*

HTTP is a communication protocol. It defines mechanism for communication between browser and the web server. It is also called request and response protocol because the communication between browser and server takes place in request and response pairs.

HTTP Request

HTTP request comprises of lines which contains:

- Request line
- Header Fields
- Message body

Key Points

- The first line i.e. the **Request line** specifies the request method i.e. **Get** or **Post**.
- The second line specifies the header which indicates the domain name of the server from where index.htm is retrieved.

HTTP Response

Like HTTP request, HTTP response also has certain structure. HTTP response contains:

- Status line
- Headers
- Message body
-

Email

Email is a service which allows us to send the message in electronic mode over the internet. It offers an efficient, inexpensive and real time mean of distributing information among people.

E-mail Protocols

SMTP

SMTP stands for **Simple Mail Transfer Protocol**. It was first proposed in 1982. It is a standard protocol used for sending e-mail efficiently and reliably over the internet.

Key Points:

- SMTP is application level protocol.
- SMTP is connection oriented protocol.
- SMTP is text based protocol.
- It handles exchange of messages between e-mail servers over TCP/IP network.
- Apart from transferring e-mail, SMTP also provides notification regarding incoming mail.
- When you send e-mail, your e-mail client sends it to your e-mail server which further contacts the recipient mail server using SMTP client.
- These SMTP commands specify the sender's and receiver's e-mail address, along with the message to be send.
- The exchange of commands between servers is carried out without intervention of any user.
- In case, message cannot be delivered, an error report is sent to the sender which makes SMTP a reliable protocol.

IMAP

IMAP stands for **Internet Mail Access Protocol**. It was first proposed in 1986. There exist five versions of IMAP as follows:

1. Original IMAP
2. IMAP2
3. IMAP3
4. IMAP2bis
5. IMAP4

Key Points:

- IMAP allows the client program to manipulate the e-mail message on the server without downloading them on the local computer.
- The e-mail is hold and maintained by the remote server.

- It enables us to take any action such as downloading, delete the mail without reading the mail. It enables us to create, manipulate and delete remote message folders called mail boxes.
- IMAP enables the users to search the e-mails.
- It allows concurrent access to multiple mailboxes on multiple mail servers.

POP

POP stands for Post Office Protocol. It is generally used to support a single client. There are several versions of POP but the POP 3 is the current standard.

Key Points

- POP is an application layer internet standard protocol.
- Since POP supports offline access to the messages, thus requires less internet usage time.
- POP does not allow search facility.
- In order to access the messaged, it is necessary to download them.
- It allows only one mailbox to be created on server.
- It is not suitable for accessing non mail data.
- POP commands are generally abbreviated into codes of three or four letters. Eg. STAT.

E-mail Working

Email working follows the client server approach. In this client is the mailer i.e. the mail application or mail program and server is a device that manages emails.

Following example will take you through the basic steps involved in sending and receiving emails and will give you a better understanding of working of email system:

- Suppose person A wants to send an email message to person B.
- Person A composes the messages using a mailer program i.e. mail client and then select Send option.
- The message is routed to **Simple Mail Transfer Protocol** to person B's mail server.
- The mail server stores the email message on disk in an area designated for person B.

The disk space area on mail server is called mail spool.

- Now, suppose person B is running a POP client and knows how to communicate with B's mail server.
- It will periodically poll the POP server to check if any new email has arrived for B. As in this case, person B has sent an email for person B, so email is forwarded over the network to B's PC. This is message is now stored on person B's PC.

The following diagram gives pictorial representation of the steps discussed above:

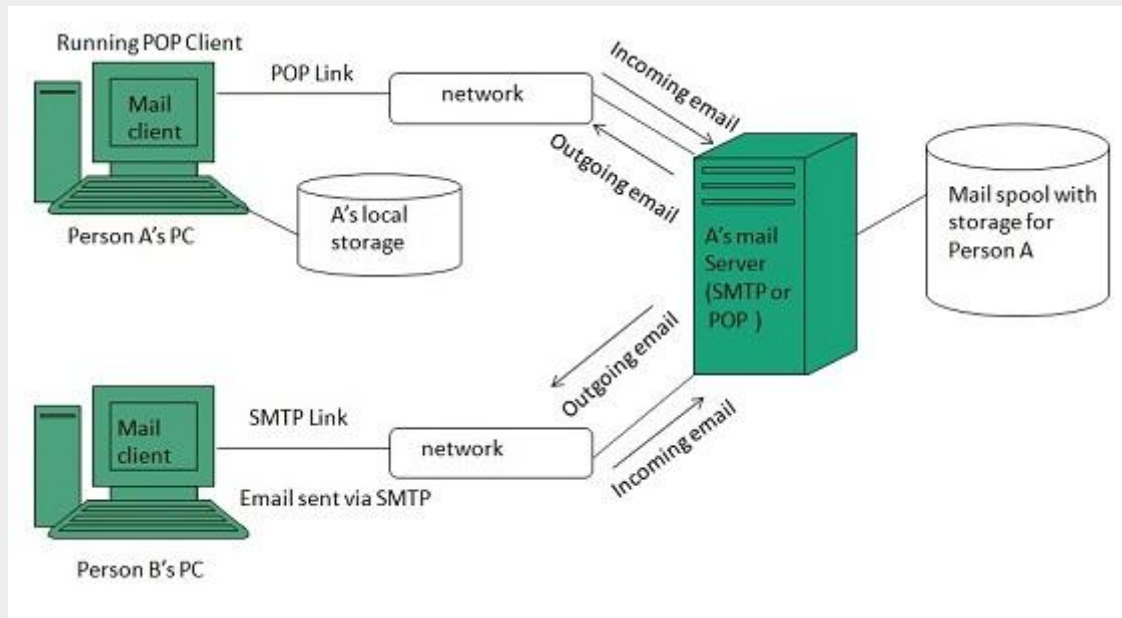

E-mail Operations

Creating Email Account

There are various email service provider available such as **Gmail, hotmail, ymail, rediff mail** etc. Here we will learn how to create an account using Gmail.

- Open gmail.com and click **create an account**.
- Now a form will appear. Fill your details here and click **Next Step**.



- This step allows you to add your picture. If you don't want to upload now, you can do it later. Click **Next Step**.
- Now a welcome window appears. Click **Continue to Gmail**.
- Wow!! You are done with creating your email account with Gmail. It's that easy. Isn't it?
- Now you will see your Gmail account as shown in the following image:

Key Points:

- Gmail manages the mail into three categories namely **Primary, Social** and **Promotions**.
- **Compose** option is given at the right to compose an email message.
- **Inbox, Starred, Sent mail, Drafts** options are available on the left pane which allows you to keep track of your emails.

Composing and Sending Email

Before sending an email, we need to compose a message. When we are composing an email message, we specify the following things:

- Sender's address in To field
- *Cc if required*
- *Bcc if required*
- Subject of email message
- Text
- Signature

You should specify the correct email address; otherwise it will send an error back to the sender.

Once you have specified all the above parameters, It's time to send the email. The mailer program provides a Send button to send email, when you click Send, it is sent to the mail server and a message **mail sent successfully** is shown at the above.

Reading Email

Every email program offers you an interface to access email messages. Like in Gmail, emails are stored under different tabs such as primary, social, and promotion. When you click one of tab, it displays a list of emails under that tab.

In order to read an email, you just have to click on that email. Once you click a particular email, it gets opened.

The opened email may have some file attached with it. The attachments are shown at the bottom of the opened email with an option called **download attachment**.

Replying Email

After reading an email, you may have to reply that email. To reply an email, click **Reply** option shown at the bottom of the opened email.

Once you click on Reply, it will automatically copy the sender's address in to the To field. Below the To field, there is a text box where you can type the message.

Once you are done with entering message, click Send button. It's that easy. Your email is sent.

Forwarding Email

It is also possible to send a copy of the message that you have received along with your own comments if you want. This can be done using **forward** button available in mail client software.

The difference between replying and forwarding an email is that when you reply a message to a person who has send the mail but while forwarding you can send it to anyone.

When you receive a forwarded message, the message is marked with a > character in front of each line and **Subject:** field is prefixed with **Fw.**

Deleting Email

If you don't want to keep email into your inbox, you can delete it by simply selecting the message from the message list and clicking **delete** or pressing the appropriate command.

Some mail clients offers the deleted mails to be stored in a folder called deleted items or trash from where you can recover a deleted email.

E-mail Security

E-mail Hacking

Email hacking can be done in any of the following ways:

- Spam
- Virus
- Phishing

Spam

E-mail spamming is an act of sending **Unsolicited Bulk E-mails UBI** which one has not asked for. Email spams are the junk mails sent by commercial companies as an advertisement of their products and services.

Virus

Some emails may incorporate with files containing malicious script which when run on your computer may lead to destroy your important data.

Phishing

Email phishing is an activity of sending emails to a user claiming to be a legitimate enterprise. Its main purpose is to steal sensitive information such as usernames, passwords, and credit card details.

Such emails contains link to websites that are infected with malware and direct the user to enter details at a fake website whose look and feels are same to legitimate one.

E-mail Spamming and Junk Mails

Email spamming is an act of sending Unsolicited Bulk E-mails *UBI* which one has not asked for. Email spams are the junk mails sent by commercial companies as an advertisement of their products and services.

Spams may cause the following problems:

- It floods your e-mail account with unwanted e-mails, which may result in loss of important e-mails if inbox is full.
- Time and energy is wasted in reviewing and deleting junk emails or spams.
- It consumes the bandwidth that slows the speed with which mails are delivered.
- Some unsolicited email may contain virus that can cause harm to your computer.

Blocking Spams

Following ways will help you to reduce spams:

- While posting letters to newsgroups or mailing list, use a separate e-mail address than the one you used for your personal e-mails.
- Don't give your email address on the websites as it can easily be spammed.
- Avoid replying to emails which you have received from unknown persons.
- Never buy anything in response to a spam that advertises a product.

E-mail Cleanup and Archiving

In order to have light weighted Inbox, it's good to archive your inbox from time to time. Here I will discuss the steps to clean up and archive your Outlook inbox.

- Select **File** tab on the mail pane.
- Select **Cleanup Tools** button on account information screen.
- Select **Archive** from cleanup tools drop down menu.
- Select **Archive this folder and all subfolders** option and then click on the folder that you want to archive. Select the date from the **Archive items older than:** list. Click **Browse** to create new **.pst** file name and location. Click **OK**.

E-mail Providers

There are several email service providers available in the market with their enabled features such as sending, receiving, drafting, storing an email and much more.

The following table shows the popular email service providers:

S.N.	Service and Description
------	-------------------------

- | | |
|----|--|
| 1. | Gmail
Gmail is an email service that allows users to collect all the messages. It also offers approx |
|----|--|

7 GB of free storage.

2. **Hotmail**
Hotmail offers free email and practically unlimited storage accessible on web.
3. **Yahoo Mail**
Yahoo Mail offers unlimited storage, SMS texting, social networking and instant messaging to boot.
4. **iCloud Mail**
iCloud Mail offers ample storage, IMAP access, and an elegantly functional web application.
5. **ATM Mail**
ATM Mail is a free email service with good spam protection.
6. **Mail.com and GMX Mail**
Mail.com and GMX Mail offers reliable mail service with unlimited online storage.
7. **Shortmail**
Shortmail offers easy and fast email service but with limited 500 characters per message.
8. **Inbox.com**
Inbox.com offers 5 GB of free online storage. IMAP is not supported by Inbox.com
9. **Facebook Messages**
Facebook Messages includes the message conversation.
10. **My Way Mail**
My Way Mail offers clean and fast free email service but lacks in secure messaging.

Website Designing

Web designing has direct link to visual aspect of a web site. Effective web design is necessary to communicate ideas effectively.

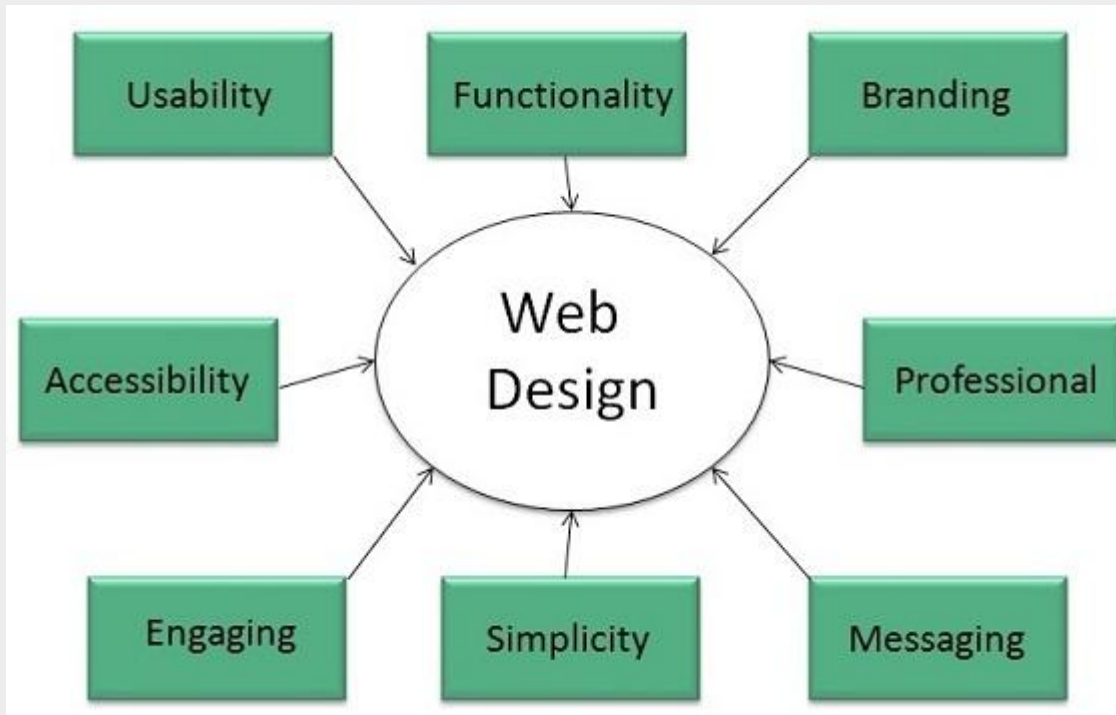

Web desinging is subset of web development. However these terms are used interchangeably.

Key Points

Design Plan should include the following:

- Details about information architecture.
- Planned structure of site.
- A site map of pages

Wireframe

Wireframe refers to a visual guide to appearance of web pages. It helps to define structre of web site, linking between web pages and layout of visual elements.

Following things are included in a wireframe:

- Boxes of primary graphical elements
- Placement of headlines and sub headings
- Simple layout structure
- Calls to action
- Text blocks

Wireframe can be created using program like Visio but you can also use a pen and paper.

Web Designing Tools

Here is the list of tools that can be used to make effective web designs:

- Photoshop CC
- Illustrator CC
- Coda 2
- OmniGraffle
- Sublime Text
- GitHub
- Pen and Parer
- Vim
- Imageoptim
- Sketch 3
- Heroku
- Axure
- Hype 2
- Slicy
- Framer.js
- Image Alpha
- Emmet LiveStyle
- Hammer
- Icon Slate
- JPEGmini Lite
- BugHerd

Web Page Anatomy

A web site includes the following components:

Containing Block

Container can be in the form of page's body tag, an all containing div tag. Without container there would be no place to put the contents of a web page.

Logo

Logo refers to the identity of a website and is used across a company's various forms of marketing such as business cards, letterhead, brochures and so on.

Naviagation

The site's **navigation system** should be easy to find and use. Oftenly the anvigation is placed righth at the top of the page.

Content

The content on a web site should be relevant to the purpose of the web site.

Footer

Footer is located at the bottom of the page. It usually contains copyright, contract and legal information as well as few links to the main sections of the site.

Whitespace

It is also called as **negative space** and refers to any area of page that is not covered by type or illustrations.

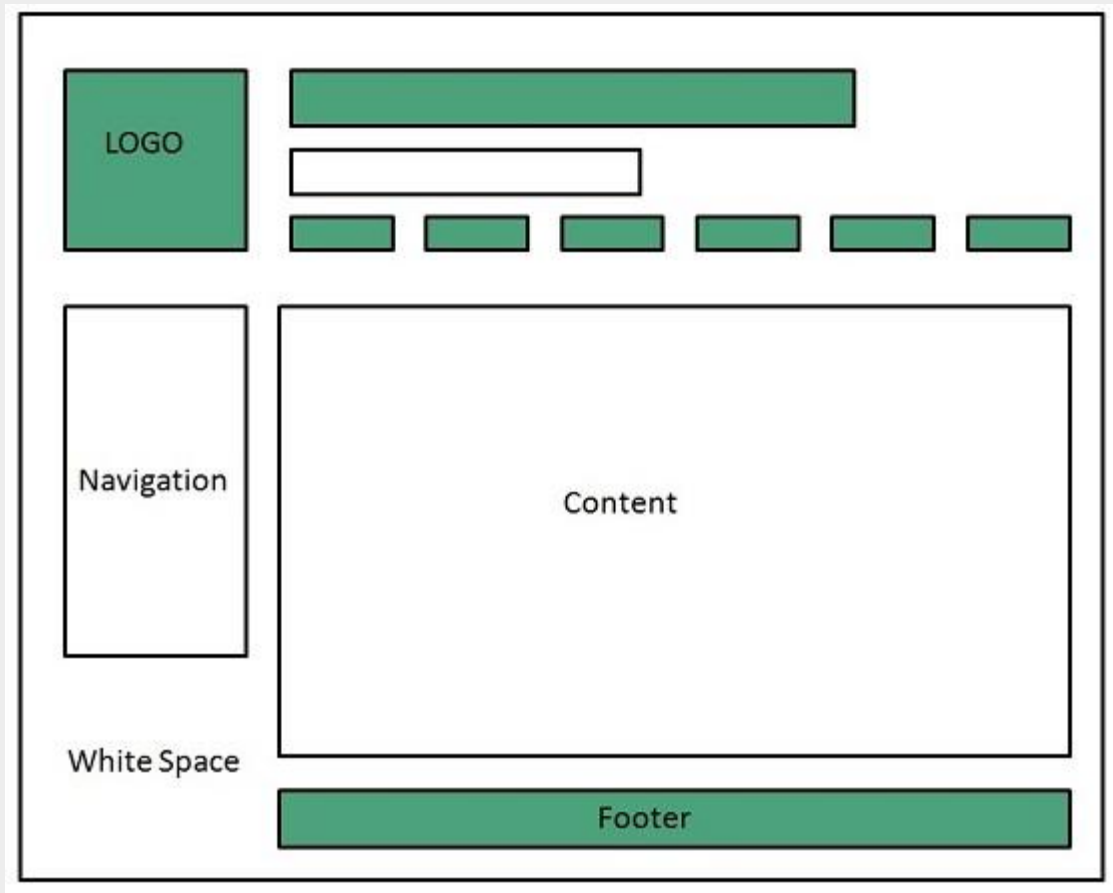

Web design Mistakes

One should be aware of the following common mistakes should always keep in mind:

- Website not working in any other browser other internet explorer.
- Using cutting edge technology for no good reason
- Sound or video that starts automatically
- Hidden or disguised navigation
- 100% flash content.

Web development

Web development refers to building website and deploying on the web. Web development requires use of scripting languages both at the server end as well as at client end.

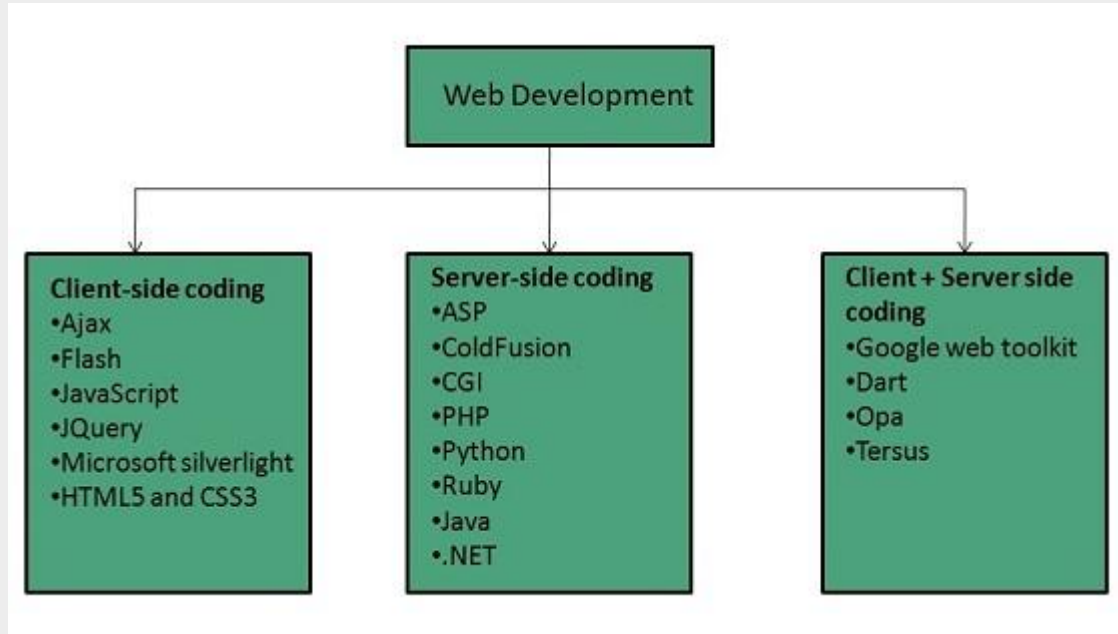

Before developing a web site once should keep several aspects in mind like:

- What to put on the web site?
- Who will host it?
- How to make it interactive?
- How to code it?
- How to create search engine friendly web site?
- How to secure the source code frequently?
- Will the web site design display well in different browsers?
- Will the navigation menus be easy to use?
- Will the web site loads quickly?
- How easily will the site pages print?
- How easily will visitors find important details specific to the web site?
- How effectively the style sheets be used on your web sites?

Web Development Process

Web development process includes all the steps that are good to take to build an attractive, effective and responsive website. These steps are shown in the following diagram:

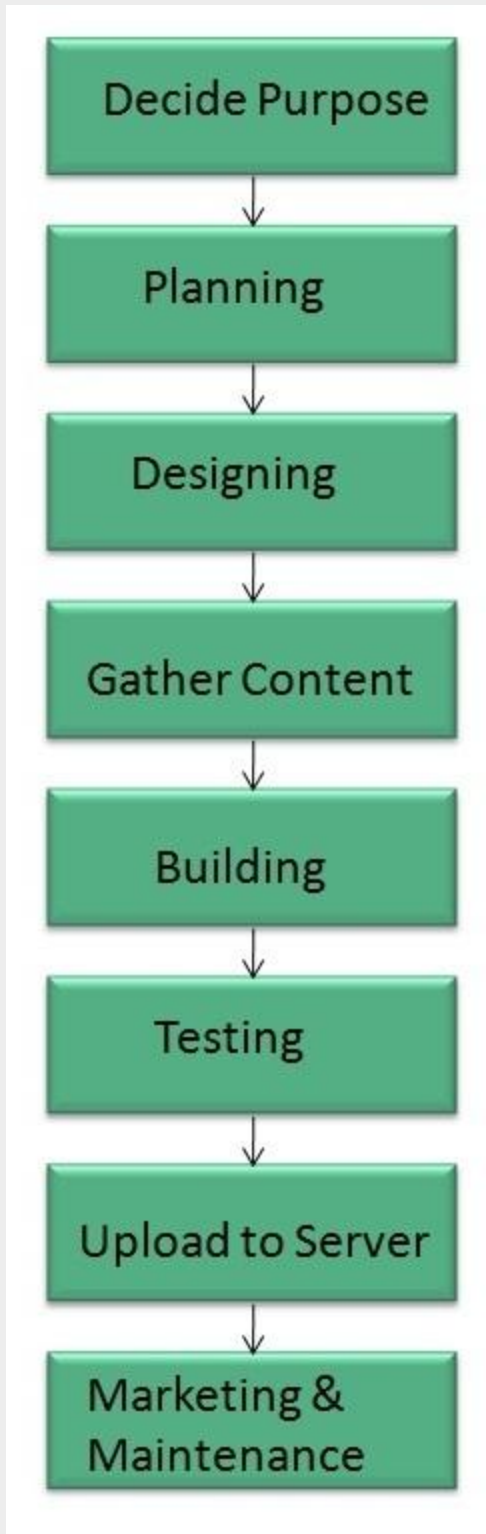

Web development tools

Web development tools help the developer to test and debug the web sites. Now a days the web development tools come with the web browsers as add-ons. All web browsers have built in tools for this purpose.

These tools allow the web developer to use HTML, CSS and JavaScript etc.. These are accessed by hovering over an item on a web page and selecting the “Inspect Element” from the context menu.

Features

Following are the common features that every web development tool exhibits:

HTML and the DOM

HTML and DOM viewer allows you to see the DOM as it was rendered. It also allows to make changes to HTML and DOM and see the changes reflected in the page after the change is made.

Web Page Assests, Resources, and Network Information

Web development tools also help to inspect the resources that are loaded and available on the web page.

Profiling and Auditing

Profiling refers to get information about the performance of a web page or web application and **Auditing** provides developers suggestions, after analyzing a page, for optimizations to decrease page load time and increase responsiveness.

Skills Required

For being a successful web developer, one should possess the following skills:

- Understanding of client and server side scripting.
- Creating, editing and modifying templates for a CMS or web development framework.
- Testing cross browser inconsistencies.
- Conducting observational user testing.
- Testing for compliance to specified standards such as accessibility standards in the client region.
- Programming interaction with JavaScript, PHP, and JQuery etc.

Websites Hosting

Web hosting is a service of providing online space for storage of web pages. These web pages are made available via **World Wide Web**. The companies which offer website hosting are known as **Web hosts**.

The servers on which web site is hosted remain switched on 24 x7. These servers are run by web hosting companies. Each server has its own IP address. Since IP addresses are difficult to remember therefore, webmaster points their domain name to the IP address of the server their website is stored on.

It is not possible to host your website on your local computer, to do so you would have to leave your computer on 24 hours a day. This is not practical and cheaper as well. This is where web hosting companies comes in.

Types of Hosting

The following table describes different types of hosting that can be availed as per the need:

S.N.	Hosting Description
	Shared Hosting
1.	In shared hosting, the hosting company puts thousand of website on the same physical server. Each customer has their own allocation of physical web space and a set of bandwidth limit. As all websites share same physical memory, MYSQL server and Apache server, one website on the server experiencing high traffic load will affect performance of all websites on the server.
	Virtual Private Server VPS
2.	It is also known as Virtual Dedicated Server. It is a server which is partitioned into smaller servers. In this customer is given their own partition, which is installed with its own operating system. Unlike shared hosting, VPS doesn't share memory or processor time rather it allocates certain amount of memory and CPU to use which means that any problem on a VPS partition on the same drive will not affect other VPS customers.
	Dedicated Server
3.	In this kind of hosting, single dedicated server is setup for just one customer. It is commonly used by the businesses that need the power, control and security that a dedicated server offers.
	Reseller Hosting
4.	A reseller acts as a middle man and sells hosting space of someone else's server.
	Grid Hosting
5.	Instead of utilizing one server, Grid Hosting spreads resources over a large number of servers. It is quite stable and flexible. The servers can be added or taken away from the grid without crashing the system.

Web Hosting Companies

Following are the several companies offering web hosting service:

S.N. Hosting Company

1. Blue Host
2. Go Daddy

3. Host Gator
4. just Host
5. Laughing Squid
6. Hivelocity
7. liquid Web
8. Media TempleServInt
9. Wired Tree
10. Wild West Domains
11. Wix
12. WIPL
13. Big Rock

Website Security Considerations

Websites are always to prone to security risks. **Cyber crime** impacts your business by hacking your website. Your website is then used for hacking assaults that install malicious software or malware on your visitor's computer.

Hackers may also steal important customer data such as credit card information, destroy your business and propagate illegal content to your users.

Security Considerations

Updated Software

It is mandatory to keep you software updated. It plays vital role in keeping your website secure.

SQL Injection

It is an attempt by the hackers to manipulate your database. It is easy to insert rogue code into your query that can be used to manipulate your database such as change tables, get information or delete data.

Cross Site Scripting XSS

It allows the attackers to inject client side script into web pages. Therefore, while creating a form It is good to endure that you check the data being submitted and encode or strip out any HTML.

Error Messages

You need to be careful about how much information to be given in the error messages. For example, if the user fails to log in the error message should not let the user know which field is incorrect: username or password.

Validation of Data

The validation should be performed on both server side and client side.

Passwords

It is good to enforce password requirements such as of minimum of eight characters, including upper case, lower case and special character. It will help to protect user's information in long run.

Upload files

The file uploaded by the user may contain a script that when executed on the server opens up your website.

SSL

It is good practice to use SSL protocol while passing personal information between website and web server or database.

World Wide Web

A technical definition of the World Wide Web is : all the resources and users on the Internet that are using the Hypertext Transfer Protocol *HTTP*.

A broader definition comes from the organization that Web inventor **Tim Berners-Lee** helped found, the **World Wide Web Consortium W3C**.

The World Wide Web is the universe of network-accessible information, an embodiment of human knowledge.

In simple terms, The World Wide Web is a way of exchanging information between computers on the Internet, tying them together into a vast collection of interactive multimedia resources.

Internet and **Web** is not the same thing: Web uses internet to pass over the information.

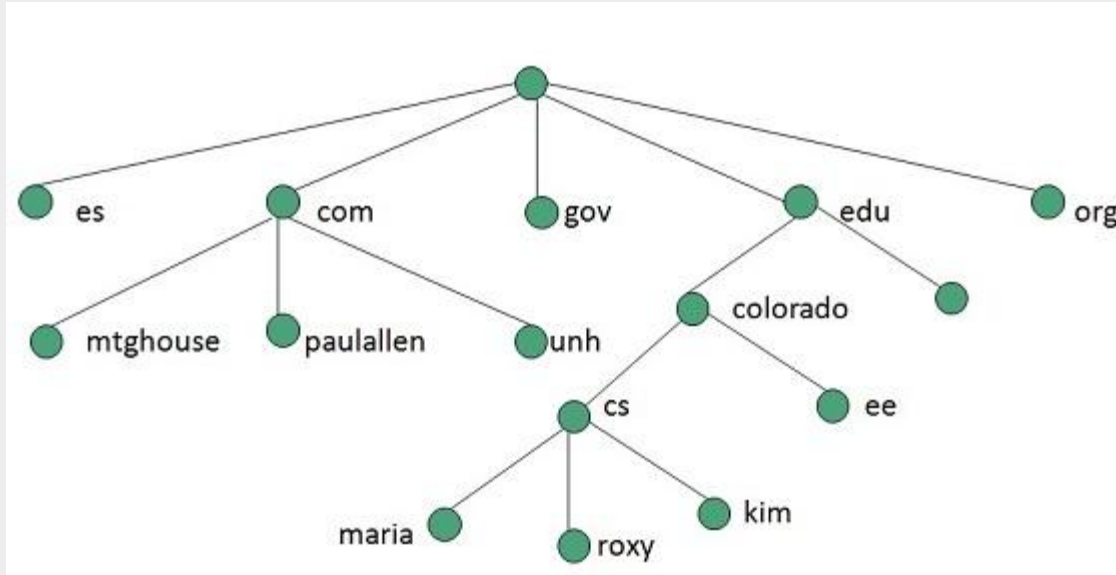

WWW Evolution

World Wide Web was created by **Timothy Berners Lee** in 1989 at **CERN** in **Geneva**. World Wide Web came into existence as a proposal by him, to allow researchers to work together effectively and efficiently at **CERN**. Eventually it became **World Wide Web**.

The following diagram briefly defines evolution of World Wide Web:

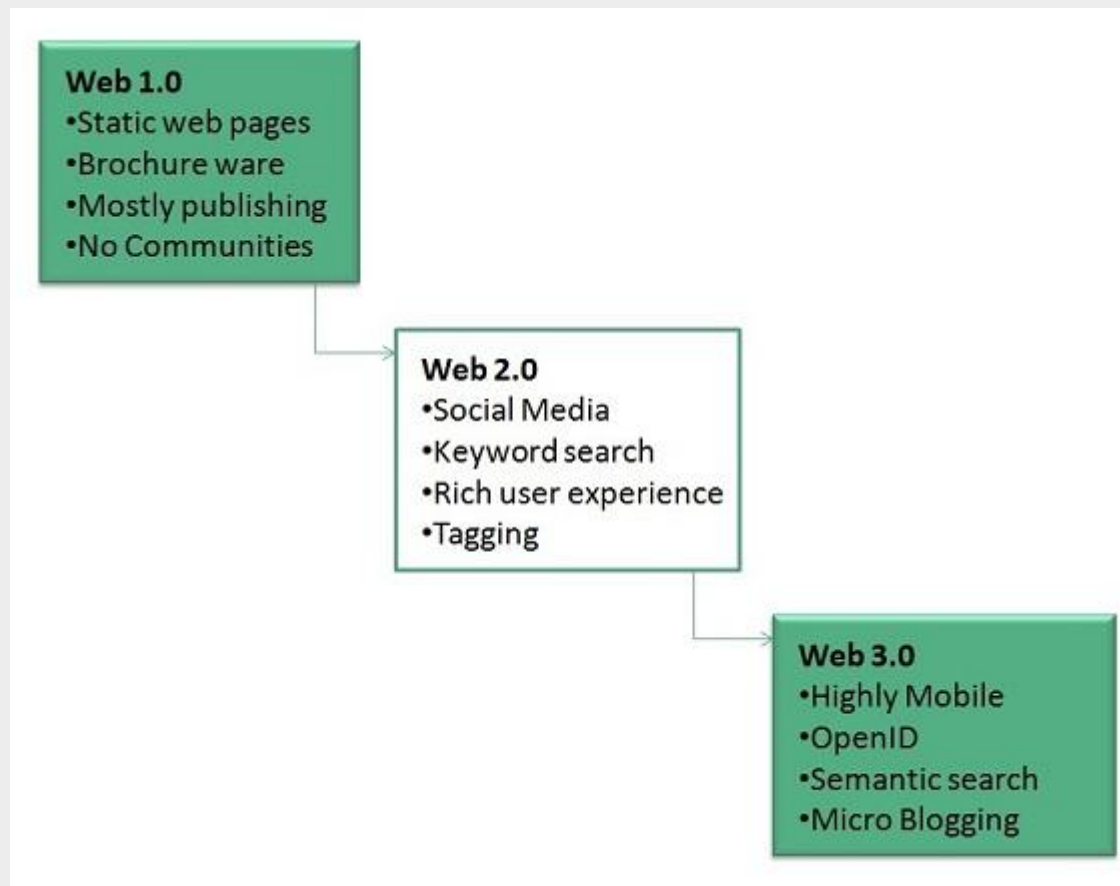

WWW Architecture

WWW architecture is divided into several layers as shown in the following diagram:

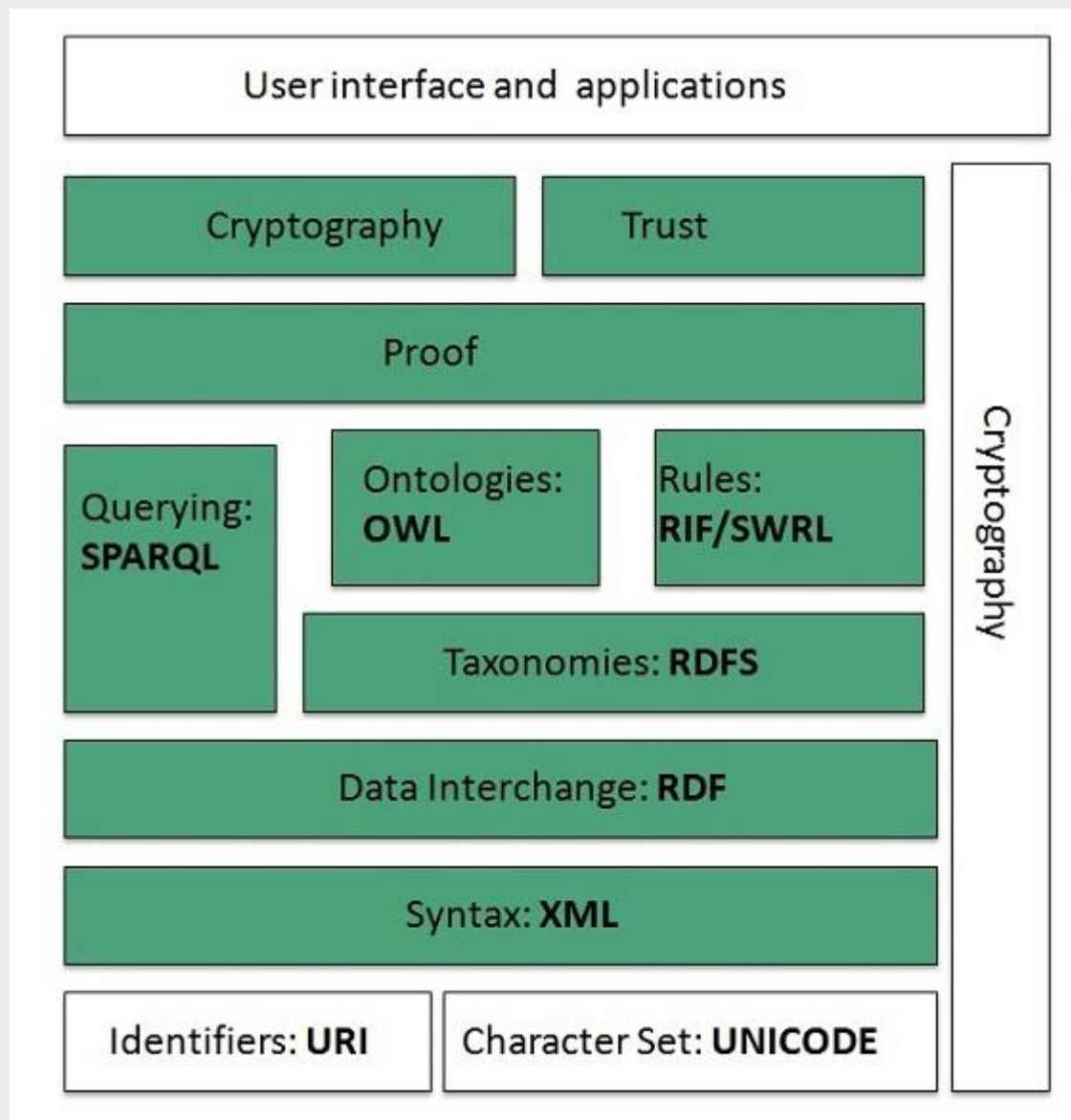

Identifiers and Character Set

Uniform Resource Identifier *URI* is used to uniquely identify resources on the web and **UNICODE** makes it possible to built web pages that can be read and write in human languages.

Syntax

XML *ExtensibleMarkupLanguage* helps to define common syntax in semantic web.

Data Interchange

Resource Description Framework *RDF* framework helps in defining core representation of data for web. RDF represents data about resource in graph form.

Taxonomies

RDF Schema *RDFS* allows more standardized description of **taxonomies** and other **ontological** constructs.

Ontologies

Web Ontology Language *OWL* offers more constructs over **RDFS**. It comes in following three versions:

- **OWL Lite** for taxonomies and simple constraints.
- **OWL DL** for full description logic support.
- **OWL** for more syntactic freedom of **RDF**

Rules

RIF and **SWRL** offers rules beyond the constructs that are available from **RDFs** and **OWL**. Simple Protocol and **RDF Query Language *SPARQL*** is SQL like language used for querying **RDF** data and **OWL** Ontologies.

Proof

All semantic and rules that are executed at layers below **Proof** and their result will be used to prove deductions.

Cryptography

Cryptography means such as digital signature for verification of the origin of sources is used.

User Interface and Applications

On the top of layer **User interface and Applications** layer is built for user interaction.

WWW Operation

WWW works on client- server approach. Following steps explains how the web works:

1. User enters the URL (say, **http://www.tutorialspoint.com**) of the web page in the address bar of web browser.
2. Then browser requests the Domain Name Server for the IP address corresponding to **www.tutorialspoint.com**.
3. After receiving IP address, browser sends the request for web page to the web server using **HTTP** protocol which specifies the way the browser and web server communicates.
4. Then web server receives request using **HTTP** protocol and checks its search for the requested web page. If found it returns it back to the web browser and close the **HTTP** connection.

5. Now the web browser receives the web page, It interprets it and display the contents of web page in web browser's window.

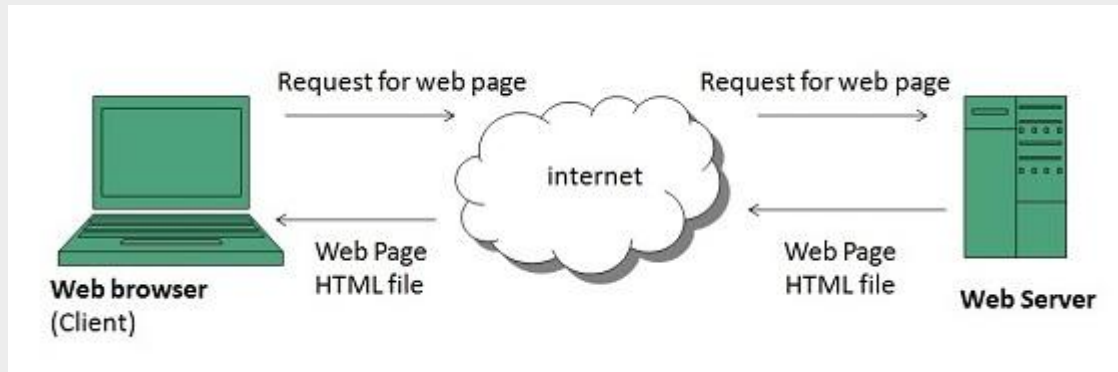

WWW Future

There had been a rapid development in field of web. It has its impact in almost every area such as education, research, technology, commerce, marketing etc. So the future of web is almost unpredictable.

Apart from huge development in field of WWW, there are also some technical issues that W3 consortium has to cope up with.

User Interface

Work on higher quality presentation of 3-D information is under deveopment. The W3 Consortium is also looking forward to enhance the web to full fill requirements of global communities which would include all regional languages and writing systems.

Technology

Work on privacy and security is under way. This would include hiding information, accounting, access control, integrity and risk management.

Architecture

There has been huge growth in field of web which may lead to overload the internet and degrade its performance. Hence more better protocol are required to be developed.

Web Browsers

web Browser is an application software that allows us to view and explore information on the web. User can request for any web page by just entering a URL into address bar.

Web browser can show text, audio, video, animation and more. It is the responsibility of a web browser to interpret text and commands contained in the web page.

Earlier the web browsers were text-based while now a days graphical-based or voice-based web browsers are also available. Following are the most common web browser available today:

Browser	Vendor
Internet Explorer	Microsoft
Google Chrome	Google
Mozilla Firefox	Mozilla
Netscape Navigator	Netscape Communications Corp.
Opera	Opera Software
Safari	Apple
Sea Monkey	Mozilla Foundation
K-meleon	K-meleon

Architecture

There are a lot of web browser available in the market. All of them interpret and display information on the screen however their capabilities and structure varies depending upon implementation. But the most basic component that all web browser must exhibit are listed below:

- Controller/Dispatcher
- Interpreter
- Client Programs

Controller works as a control unit in CPU. It takes input from the keyboard or mouse, interpret it and make other services to work on the basis of input it receives.

Interpreter receives the information from the controller and execute the instruction line by line. Some interpreter are mandatory while some are optional For example, HTML interpreter program is mandatory and java interpreter is optional.

Client Program describes the specific protocol that will be used to access a particular service. Following are the client programs tat are commonly used:

- HTTP
- SMTP
- FTP
- NNTP
- POP

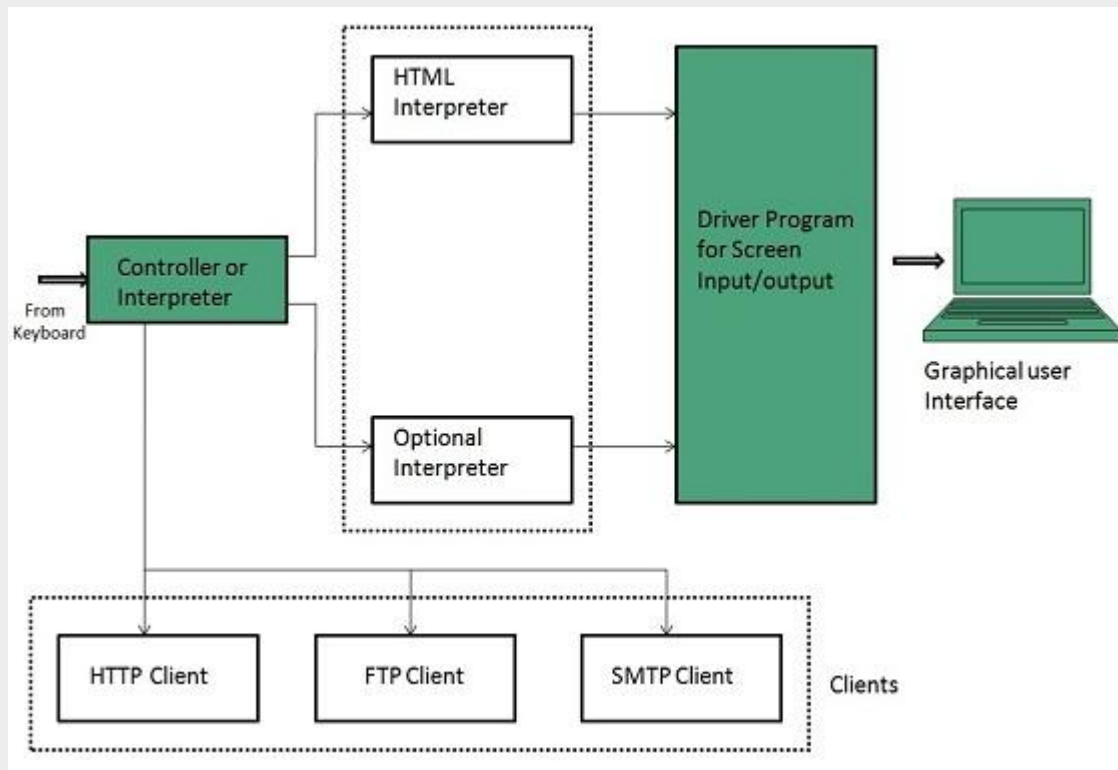

Web Server

Web server is a computer where the web content is stored. Basically web server is used to host the web sites but there exists other web servers also such as gaming, storage, FTP, email etc.

Web site is collection of web pages while web server is a software that respond to the request for web resources.

Web Server Working

Web server respond to the client request in either of the following two ways:

- Sending the file to the client associated with the requested URL.
- Generating response by invoking a script and communicating with database

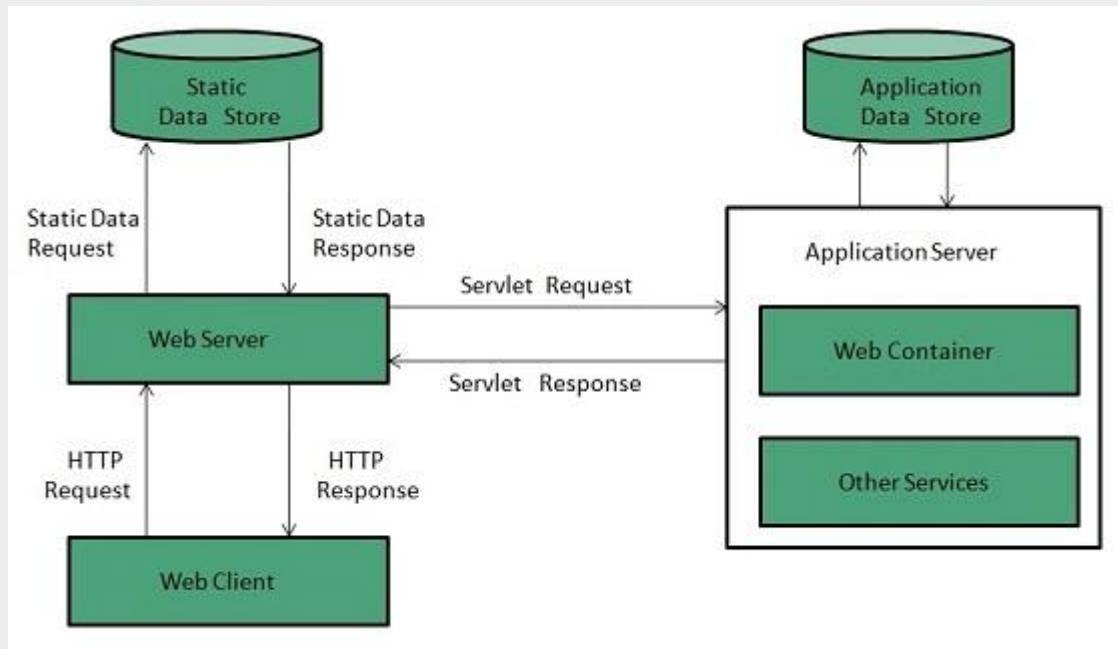

Key Points

- When client sends request for a web page, the web server search for the requested page if requested page is found then it will send it to client with an HTTP response.
- If the requested web page is not found, web server will the send an **HTTP response:Error 404 Not found**.
- If client has requested for some other resources then the web server will contact to the application server and data store to construct the HTTP response.

Architecture

Web Server Architecture follows the following two approaches:

1. Concurrent Approach
2. Single-Process-Event-Driven Approach.

Concurrent Approach

Concurrent approach allows the web server to handle multiple client requests at the same time. It can be achieved by following methods:

- Multi-process
- Multi-threaded
- Hybrid method.

Multi-processing

In this a single process *parentprocess* initiates several single-threaded child processes and distribute incoming requests to these child processes. Each of the child processes are responsible for handling single request.

It is the responsibility of parent process to monitor the load and decide if processes should be killed or forked.

Multi-threaded

Unlike Multi-process, it creates multiple single-threaded process.

Hybrid

It is combination of above two approaches. In this approach multiple process are created and each process initiates multiple threads. Each of the threads handles one connection. Using multiple threads in single process results in less load on system resources.

Examples

Following table describes the most leading web servers available today:

S.N.

Web Server Descriptino

Apache HTTP Server

- This is the most popular web server in the world developed by the Apache Software Foundation. Apache web server is an open source software and can be installed on almost all operating systems including Linux, UNIX, Windows, FreeBSD, Mac OS X and more. About 60% of the web server machines run the Apache Web Server.

Internet Information Services IIS

- The Internet Information Server *IIS* is a high performance Web Server from Microsoft. This web server runs on Windows NT/2000 and 2003 platforms *and maybe on upcoming new Windows version also*. IIS comes bundled with Windows NT/2000 and 2003; Because IIS is tightly integrated with the operating system so it is relatively easy to administer it.

Lighttpd

- The lighttpd, pronounced lighty is also a free web server that is distributed with the FreeBSD operating system. This open source web server is fast, secure and consumes much less CPU power. Lighttpd can also run on Windows, Mac OS X, Linux and Solaris operating systems.

Sun Java System Web Server

- This web server from Sun Microsystems is suited for medium and large web sites. Though the server is free it is not open source. It however, runs on Windows, Linux and UNIX platforms. The Sun Java System web server supports various languages, scripts and technologies required for Web 2.0 such as JSP, Java Servlets, PHP, Perl, Python, and Ruby on Rails, ASP and Coldfusion etc.

5. **Jigsaw Server**

Jigsaw *W3C'sServer* comes from the World Wide Web Consortium. It is open source and free and can run on various platforms like Linux, UNIX, Windows, and Mac OS X Free BSD etc. Jigsaw has been written in Java and can run CGI scripts and PHP programs.

Proxy Server

Proxy server is an intermediary server between client and the internet. Proxy servers offers the following basic functionalities:

- Firewall and network data filtering.
- Network connection sharing
- Data caching

Proxy servers allow to hide, conceal and make your network id anonymous by hiding your IP address.

Purpose of Proxy Servers

Following are the reasons to use proxy servers:

- Monitoring and Filtering
- Improving performance
- Translation
- Accessing services anonymously
- Security

Type of Proxies

Following table briefly describes the type of proxies:

Forward Proxies

In this the client requests its internal network server to forward to the internet.

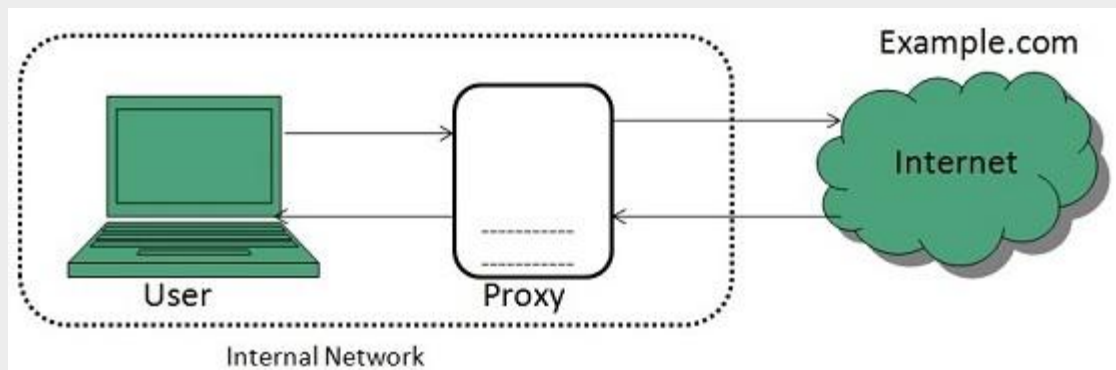

Open Proxies

Open Proxies helps the clients to conceal their IP address while browsing the web.

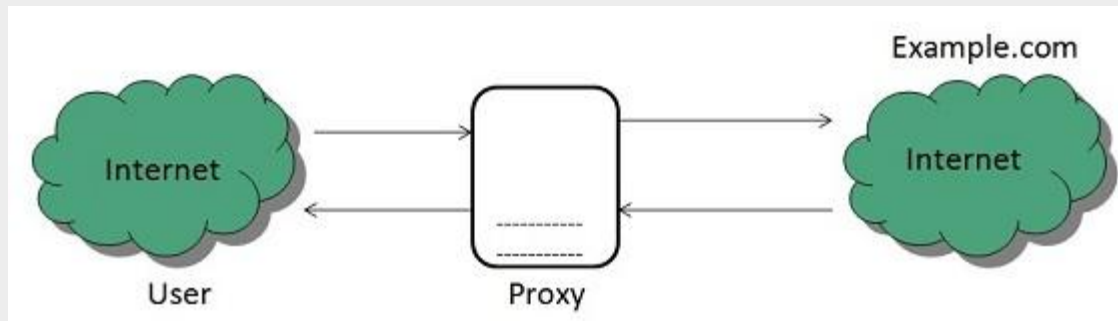

Reverse Proxies

In this the requests are forwarded to one or more proxy servers and the response from the proxy server is retrieved as if it came directly from the original Server.

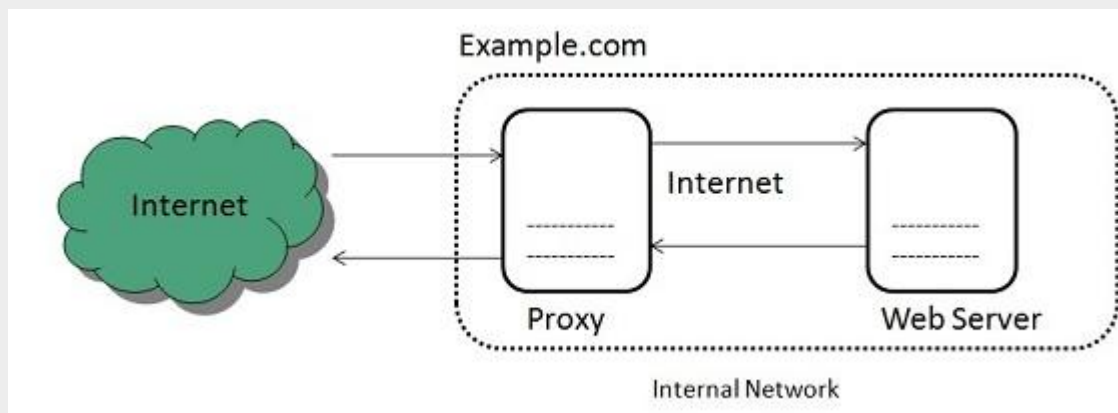

Architecture

The proxy server architecture is divided into several modules as shown in the following diagram:

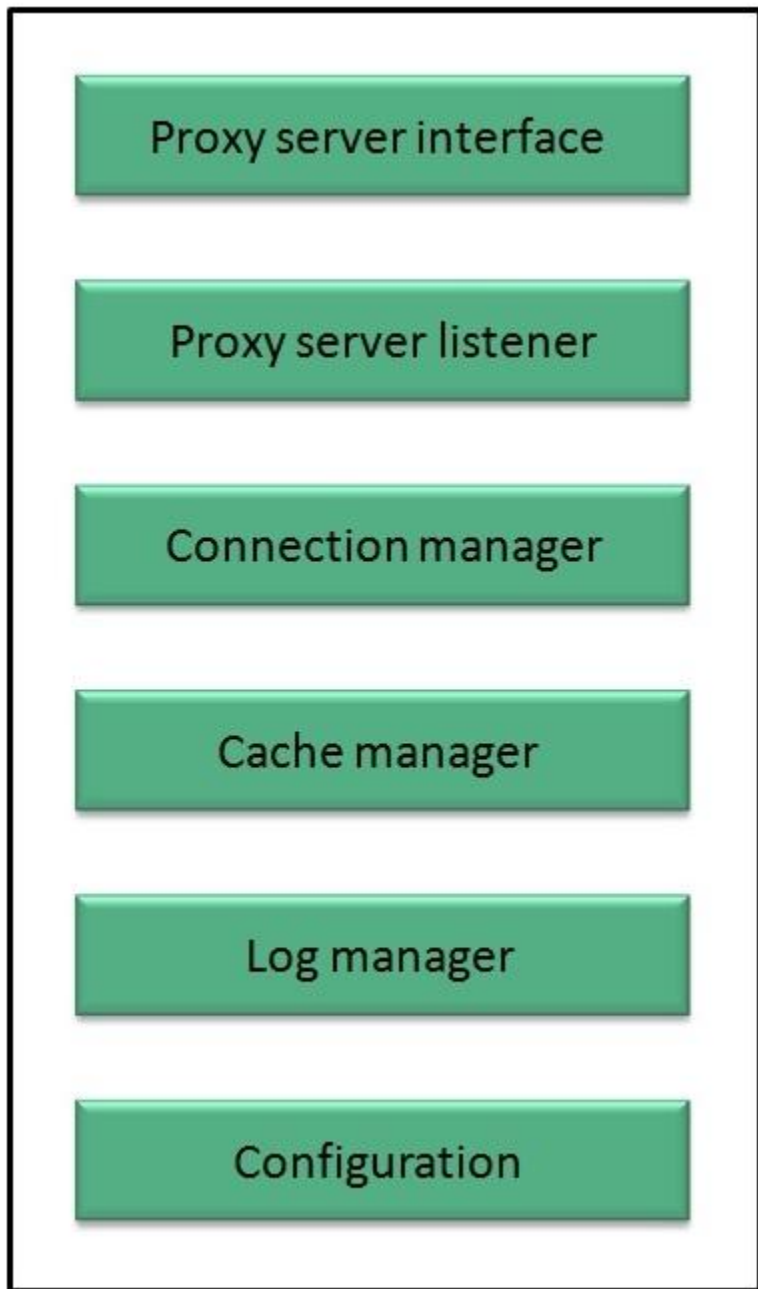

Proxy user interface

This module controls and manages the user interface and provides an easy to use graphical interface, window and a menu to the end user. This menu offers the following functionalities:

- Start proxy
- Stop proxy
- Exit
- Blocking URL

- Blocking client
- Manage log
- Manage cache
- Modify configuration

Proxy server listener

It is the port where new request from the client browser is listened. This module also performs blocking of clients from the list given by the user.

Connection Manager

It contains the main functionality of the proxy server. It performs the following functions:

- It contains the main functionality of the proxy server. It performs the following functions:
- Read request from header of the client.
- Parse the URL and determine whether the URL is blocked or not.
- Generate connection to the web server.
- Read the reply from the web server.
- If no copy of page is found in the cache then download the page from web server else will check its last modified date from the reply header and accordingly will read from the cache or server from the web.
- Then it will also check whether caching is allowed or not and accordingly will cache the page.

Cache Manager

This module is responsible for storing, deleting, clearing and searching of web pages in the cache.

Log Manager

This module is responsible for viewing, clearing and updating the logs.

Configuration

This module helps to create configuration settings which in turn let other modules to perform desired configurations such as caching.

Search Engines

Search Engine refers to a huge database of internet resources such as web pages, newsgroups, programs, images etc. It helps to locate information on World Wide Web.

User can search for any information by passing query in form of keywords or phrase. It then searches for relevant information in its database and return to the user.

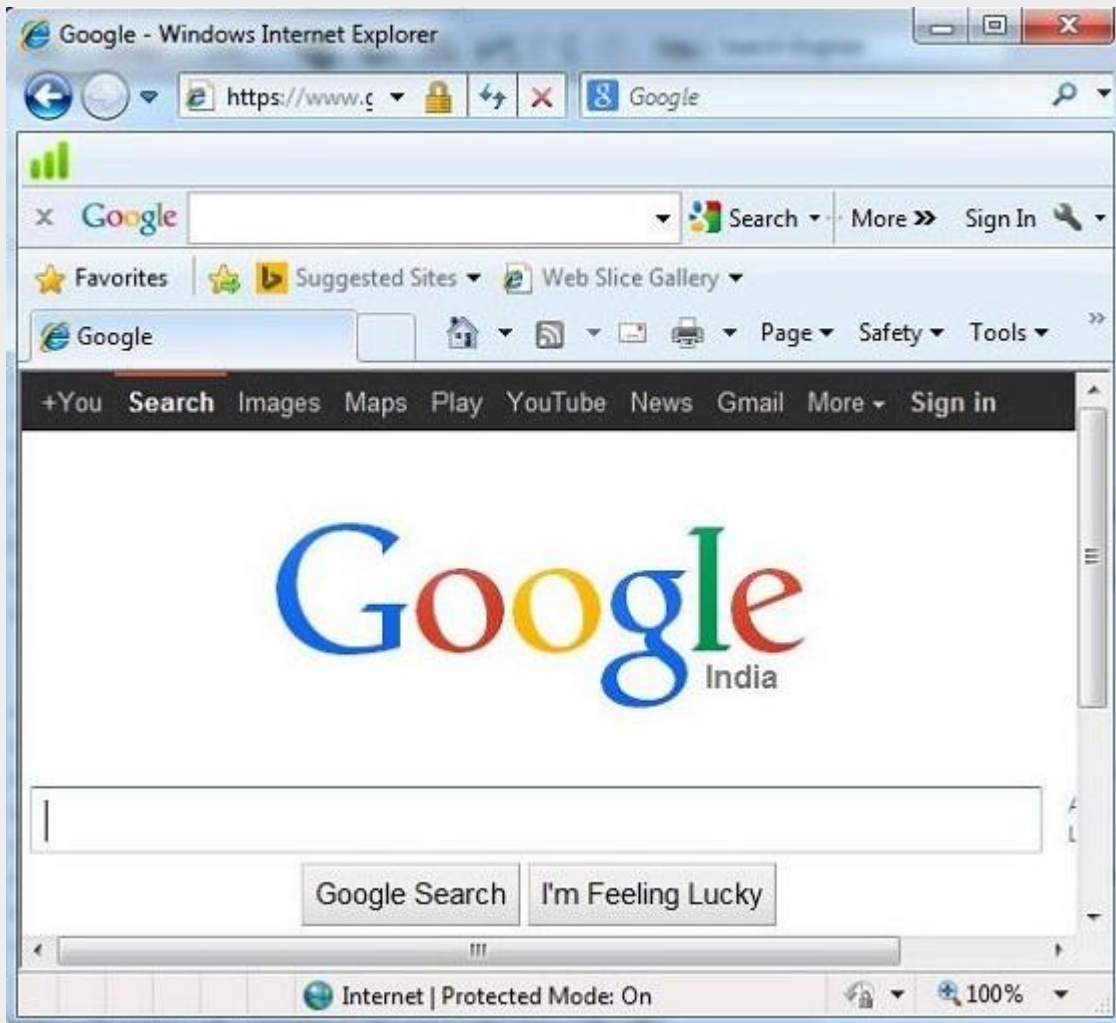

Search Engine Components

Generally there are three basic components of a search engine as listed below:

1. Web Crawler
2. Database
3. Search Interfaces

Web crawler

It is also known as **spider** or **bots**. It is a software component that traverses the web to gather information.

Database

All the information on the web is stored in database. It consists of huge web resources.

Search Interfaces

This component is an interface between user and the database. It helps the user to search through the database.

Search Engine Working

Web crawler, database and the search interface are the major component of a search engine that actually makes search engine to work. Search engines make use of Boolean expression AND, OR, NOT to restrict and widen the results of a search. Following are the steps that are performed by the search engine:

- The search engine looks for the keyword in the index for predefined database instead of going directly to the web to search for the keyword.
- It then uses software to search for the information in the database. This software component is known as web crawler.
- Once web crawler finds the pages, the search engine then shows the relevant web pages as a result. These retrieved web pages generally include title of page, size of text portion, first several sentences etc.

These search criteria may vary from one search engine to the other. The retrieved information is ranked according to various factors such as frequency of keywords, relevancy of information, links etc.

- User can click on any of the search results to open it.

Architecture

The search engine architecture comprises of the three basic layers listed below:

- Content collection and refinement.
- Search core
- User and application interfaces

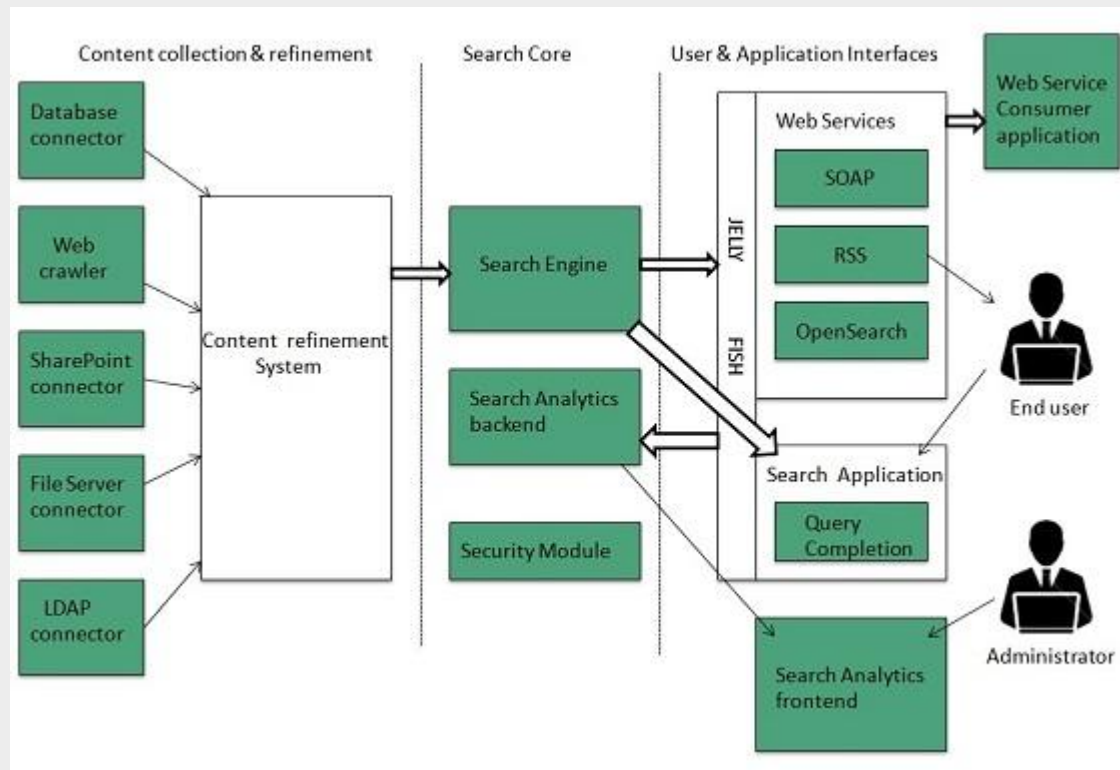

Internet Collaboration

Online Chatting

Online chatting is a text-based communication between two or more people over the network. In this, the text message is delivered in real time and people get immediate response.

Talkomatic was the world first online chat system. It was developed by **Doug Brown** and **David R. Woolley** in 1973.

Chat Etiquette

Chat etiquette defines rules that are supposed to be followed while online chatting:

- Avoid chat slang
- Try to spell all words correctly.
- Don't write all the words in capital.
- Don't send other chat users private messages without asking them.
- Abide by the rules created by those running the chat.
- Use emoticons to let other person know your feelings and expressions.

Web Based Chat Services

Following web sites offers browser based chat services:

Website	Description
Facebook	It was founded by Mark Zuckerberg with his college roommates at Harvard university. Facebook lets the user to create personal profile, post status & photos, and receive notifications.
eBuddy	It is an instant messaging service. It supports multiprotocol instant messaging clients.
Convore	It offers real time web based chat system.
MeBeam	It offers video based chat between the clients to create video conferencing rooms for up to 16 people.
Yahoo! Messenger	It offers PC-PC, PC-phone, Phone-to-PC, file transfer, webcam hosting, text messaging service etc.
WhatsApp	It is an instant messaging service application available on smart phones.
Gmail	It offers instant chatting, sending and receiving mails, and video calling services.

Instant Messaging *IM*

Instant messaging is a software utility that allows IM users to communicate by sending text messages, files, and images. Some of the IMs also support voice and video calls.

Application	Description
Nimbuzz	It is native iPhone app. It supports voice and video chats, file sharing, and group chats with panache.
eBuddy	eBuddy IM helps to have all your buddies from multiple IM accounts in one single list.
Imo.in	It has capability to link all your IM accounts together. You can log on to all of your IM accounts by just logging into imo.in.
MeBeam	It offers video based chat between the clients to create video conferencing rooms for up to 16 people.
Yahoo! Messenger	It offers PC-PC, PC-phone, Phone-to-PC, file transfer, webcam hosting, text messaging service etc.
GoogleTalk	It is an IM by Google and one of the most widely used.
Lync	Lync is an IM developed by Microsoft. It is widely used in corporate sector for internal and external communication as well.

Internet Relay Chat *IRC*

Internet Relay Chat is a protocol developed by Oikarinen in August 1988. It defines set of rules for communication between client and server by some communication mechanism such as chat rooms, over the internet.

IRC consist of separate networks of IRC servers and machines. These allow IRC clients to connect to IRC. IRC client runs a program client to connect to a server on one of the IRC nets.

After connecting to IRC server on IRC network, user can join with one or more channels and converse over there.

Video Conferencing

Video conferencing or **Video teleconferencing** is a method of communicating by two-way video and audio transmission with help of telecommunication technologies.

Modes of Video Conferencing

Point-to-Point

This mode of conferencing connects two locations only.

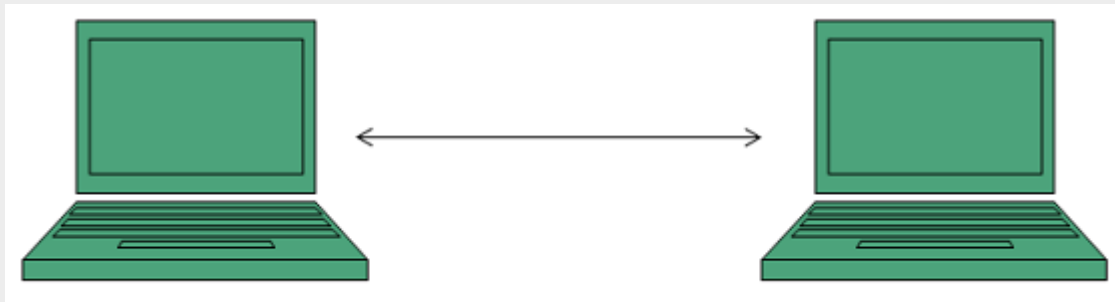

Multi-point

This mode of conferencing connects more than two locations through **Multi-point Control Unit** *MCU*.

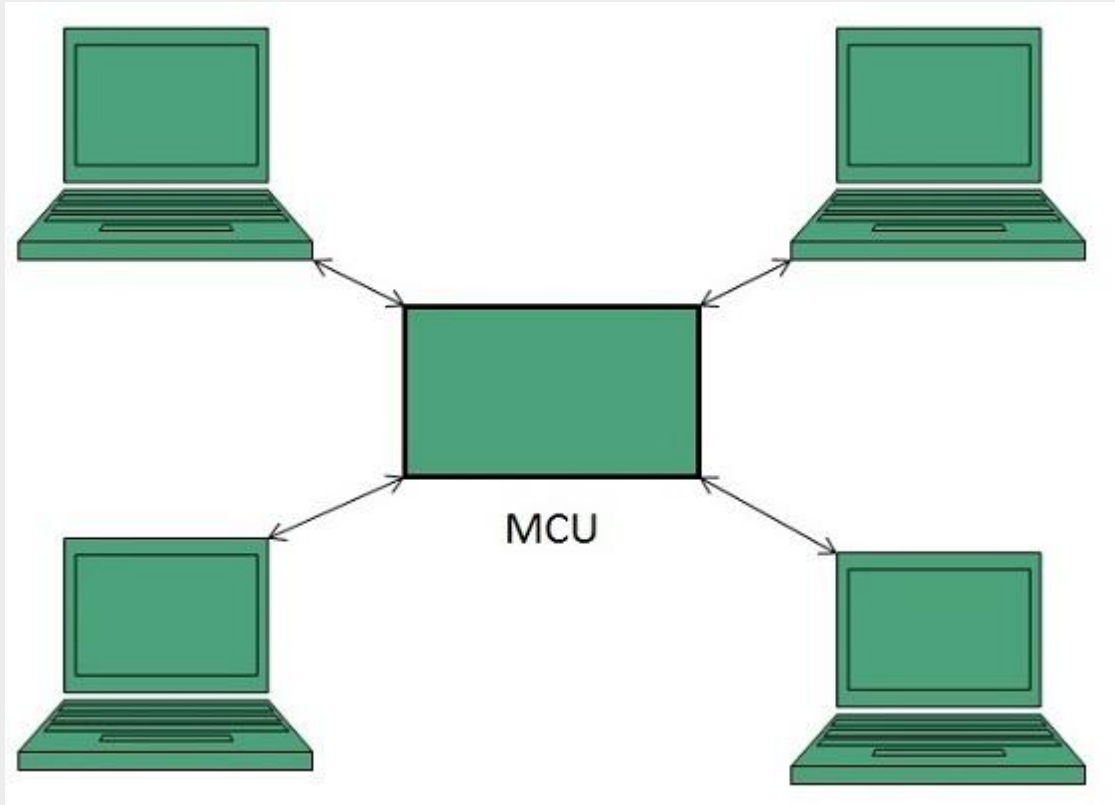

Video Sharing

Video sharing is an **IP Multimedia System IMS** service that allows user to switch voice calls to unidirectional video streaming session. The video streaming session can be initiated by any of the parties. Moreover, the video source can be the camera or the pre-recorded video clip.

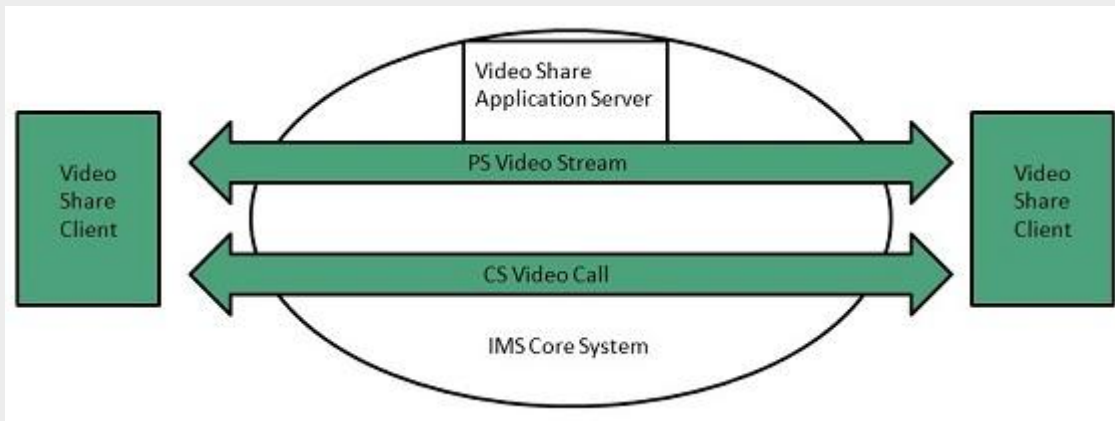

Mailing List

In order to send same email to a group of people, an electron list is created which is know as Mailing List. It is the list server which receives and distributes postings and automatically manages subscriptions.

Mailing list offers a forum, where users from all over the globe can answer questions and have them answered by others with shared interests.

Types of Mailing List

Following are the various types of mailing lists:

Response List

It contains the group of people who have responded to an offer in some way. These people are the customers who have shown interest in specific product or service.

Compiled List

The compiled list is prepared by collecting information from various sources such as surveys, telemarketing etc.

Announcements

These lists are created for sending out coupans , new product announcements and other offers to the customers.

Discussion List

This list is created for sharing views on a specific topic suchas computer, environment , healt, education etc.

How does mailing list work?

Before joining a mailing list, it is mandatory to subscribe to it. Once you are subscribed, your message will be sent to all the persons who have subscribed to the list. Similarly if any subscriber posts a message, then it will be received by all subscribers of the list.

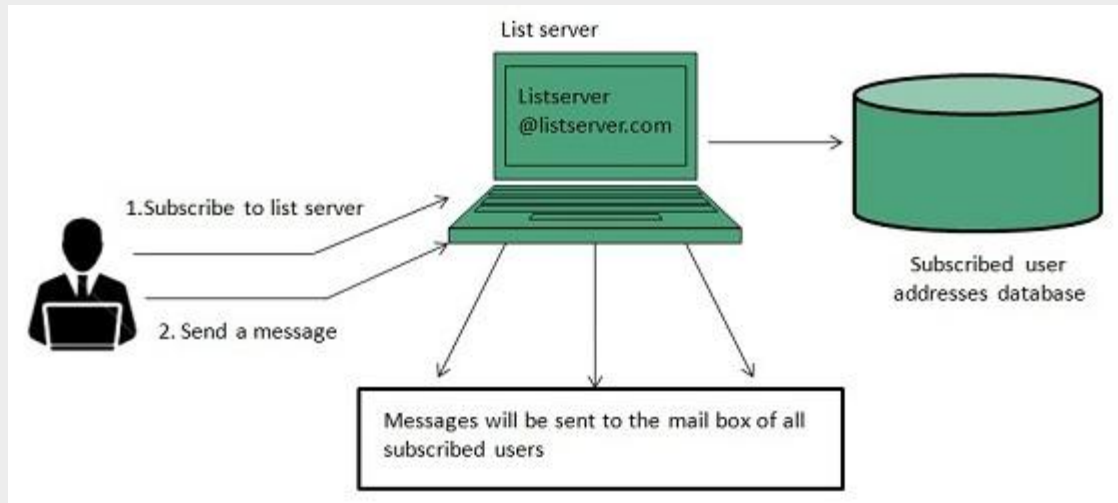

Finding Mailing List

There are a number of websites available to maintain database of publically accessible mailing list. Some of these are:

- <http://tile.net/lists>
- <http://lists.com>
- <http://topica.com>
- <http://isoft.com/lists/list-q.html>

Mailing lists can also be found using Google website. In Google, move to directory and the follow: **Computers > Internet > Mailing List > Directories.**

Subscribing to Mailing List

To subscribe to a list, you need to send an email message to the administrative address mailing list containing one or more commands. For example, if you want to subscribe to Harry Potter list in gurus.com where name of the list server us Majordomo, then you have to send email to majordom@gurus.com containing the text, Subscribe harry potter in its body.

After sending the email, you will receive a confirmation email for your subscription. This email will include list of commands that will help you to perform various operations such as unsubscribing, receiving acknowledgement, and find out what list you are subscribed to.

There are many list servers available, each having its own commands for subscribing to the list. Some of them are described in the following table:

List Server	Command	Example
LISTSERV	subscribe listname yourname	subscribe commdhtml rahul
Majordomo	subscribe listname	subscribe commdhtml

ListProc subscribe listname yourname subscribe commdhtml rahul

Usenet *USErNETwork*

Like mailing lists Usenet is also a way of sharing information. It was started by Tom Truscott and Jim Ellis in 1979. Initially it was limited to two sites but today there are thousands of Usenet sites involving millions of people.

Usenet is a kind of discussion group where people can share views on topic of their interest. The article posted to a newsgroup becomes available to all readers of the newsgroup.

Mailing list vs. Newsgroup

S.N.	Mailing List	Newsgroup
1.	Messages are delivered to individual mailboxes of subscribed member of group.	Messages are not posted to individual mailboxes but can be viewed by anyone who has subscribed to that newsgroup.
2.	Working with mailing list is easier than newsgroup. It is easy to compose and receive emails.	Working with a particular newsgroup requires proper knowledge of that newsgroup.
3.	In order to send or receive mails, you required an email program.	It requires a newsgroup reader.
4.	Messages are delivered to certain group of people.	Messages are available to public.
5.	Mailing list does not support threaded discussion.	Newsgroup supports threaded discussion.
6.	Messages delivered to listed subscribers can not be cancelled.	Article posted on a newsgroup can be cancelled.

Online Education

There are several forms of online education available as discussed below:

Online Training

Online Training is a form of distance learning in which educational information is delivered through internet. There are many online applications. These applications vary from simple downloadable content to structured programs.

Online certification

It is also possible to do online certification on specialized courses which add value to your qualification. Many companies offer online certification on a number of technologies.

There are three types of online certification as listed below:

- Corporate
- Product-specific
- Profession-wide

Corporate certifications are made by small organizations for internal purposes.

Product-specific certifications target at developing and recognizing adeptness with regard to particular product.

Profession wide certification aims at recognizing expertise in particular profession.

Online Seminar

Online seminar is the one which is conducted over the internet. It is a live seminar and allows the attendees to ask questions via Q&A panel onscreen.

Online seminar just requires a computer with internet connection, headphones, speakers, and authorization to attend it.

Webinar

Webinar is a web based seminar or workshop in which presentation is delivered over the web using conferencing software. The audio part of webinar is delivered through teleconferencing.

Conferencing

Online conferencing is also a kind of online seminar in which two or more people are involved. It is also performed over the internet. It allows the business persons to do meeting online.

Social Networking

Social Networking refers to grouping of individuals and organizations together via some medium, in order to share thoughts, interests, and activities.

There are several web based social network services are available such as facebook, twitter, linkedin, Google+ etc. which offer easy to use and interactive interface to connect with people with in the country an overseas as well. There are also several mobile based social networking services in for of apps such as Whatsapp, hike, Line etc.

Available Social networking Services

The following table describes some of the famous social networking services provided over web and mobile:

S.N.**Service Description**

1. **Facebook**
Allows to share text, photos, video etc. It also offers interesting online games.
2. **Google+**
It is pronounced as Google Plus. It is owned and operated by Google.
3. **Twitter**
Twitter allows the user to send and reply messages in form of tweets. These tweets are the small messages, generally include 140+ characters.
4. **Faceparty**
Faceparty is a UK based social networking site. It allows the users to create profiles and interact with each other using forums messages.
5. **Linkedin**
Linkedin is a business and professional networking site.
6. **Flickr**
Flickr offers image hosting and video hosting.
7. **Ibibo**
Ibibo is a talent based social networking site. It allows the users to promote one's self and also discover new talent.
8. **Whatsapp**
It is a mobile based messaging app. It allows to send text, video, and audio messages
9. **Line**
It is same as whatsapp. Allows to make free calls and messages.
10. **Hike**
It is also mobile based messenger allows to send messages and exciting emoticons.

Internet Security

Internet security refers to securing communication over the internet. It includes specific security protocols such as:

- Internet Security Protocol *IPSec*
- Secure Socket Layer *SSL*

Threats

Internet security threats impact the network, data security and other internet connected systems. Cyber criminals have evolved several techniques to threat privacy and integrity of bank accounts, businesses, and organizations.

Following are some of the internet security threats:

- Mobile worms
- Malware

- PC and Mobile ransomware
- Large scale attacks like Stuxnet that attempts to destroy infrastructure.
- Hacking as a Service
- Spam
- Phishing

Email Phishing

Email phishing is an activity of sending emails to a user claiming to be a legitimate enterprise. Its main purpose is to steal sensitive information such as usernames, passwords, and credit card details.

Such emails contains link to websites that are infected with malware and direct the user to enter details at a fake website whose look and feels are same to legitimate one.

What a phishing email may contain?

Following are the symptoms of a phishing email:

Spelling and bad grammar

Most often such emails contain grammatically incorrect text. Ignore such emails, since it can be a spam.

Beware of links in email

Don't click on any links in suspicious emails.

Threats

Such emails contain threat like "your account will be closed if you didn't respond to an email message".

Spoofing popular websites or companies

These emails contain graphics that appear to be connected to legitimate website but they actually are connected to fake websites.

Digital Signature

Digital signatures allow us to verify the author, date and time of signatures, authenticate the message contents. It also includes authentication function for additional capabilities.

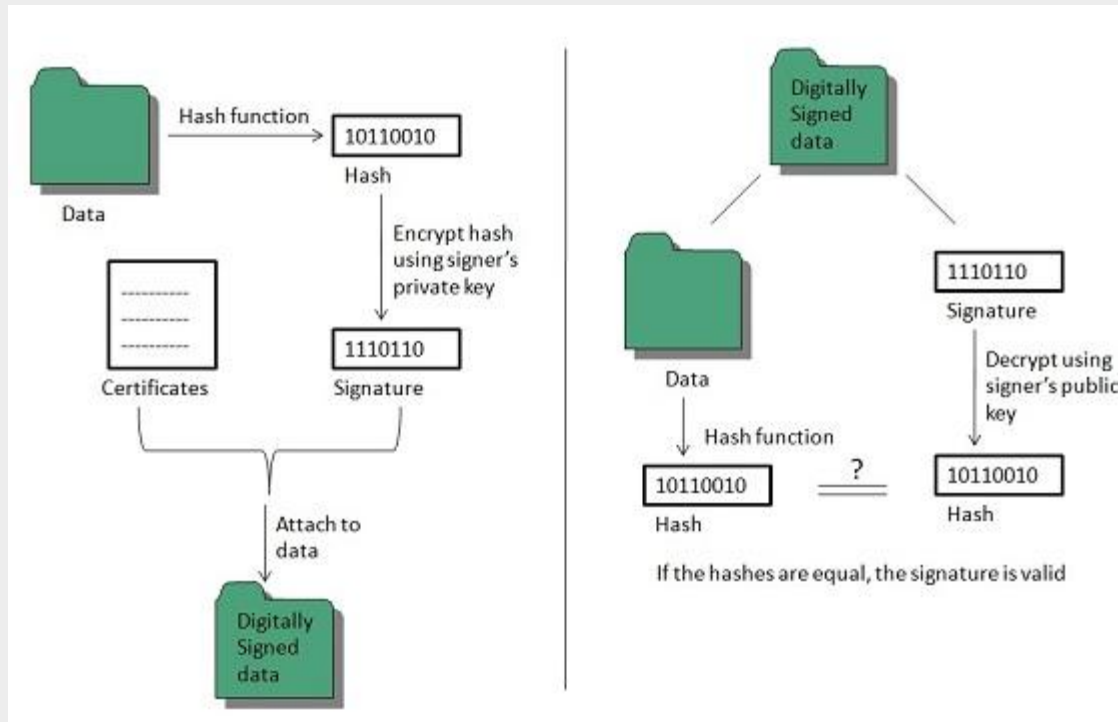

A digital signature should not only be tied to the signing user, but also to the message.

Applications

There are several reasons to implement digital signatures to communications:

Authentication

Digital signatures help to authenticate the sources of messages. For example, if a bank's branch office sends a message to central office, requesting for change in balance of an account. If the central office could not authenticate that message is sent from an authorized source, acting of such request could be a grave mistake.

Integrity

Once the message is signed, any change in the message would invalidate the signature.

Non-repudiation

By this property, any entity that has signed some information cannot at a later time deny having signed it.

Firewall Security

Firewall is a barrier between Local Area Network *LAN* and the Internet. It allows keeping private resources confidential and minimizes the security risks. It controls network traffic, in both directions.

The following diagram depicts a sample firewall between LAN and the internet. The connection between the two is the point of vulnerability. Both hardware and the software can be used at this point to filter network traffic.

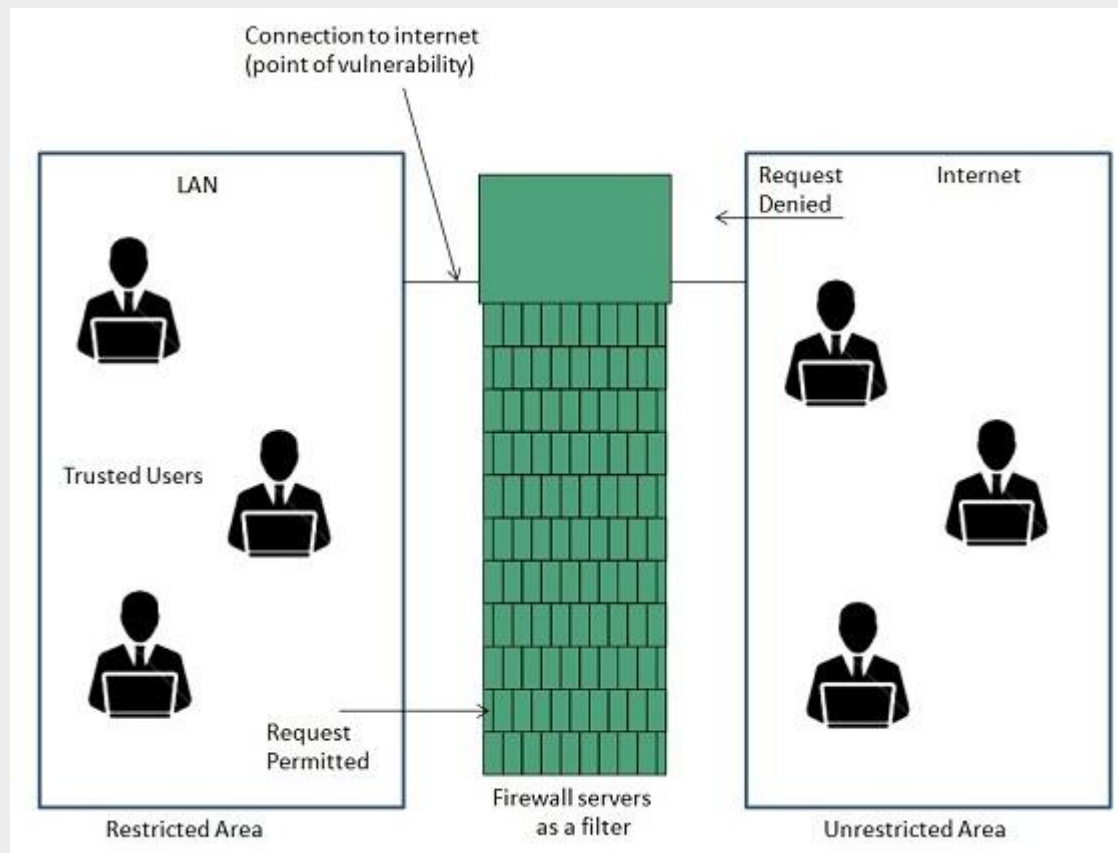

There are two types of Firewall system: One works by using filters at the network layer and the other works by using proxy servers at the user, application, or network layer.

Key Points

- Firewall management must be addressed by both system managers and the network managers.
- The amount of filtering a firewall varies. For the same firewall, the amount of filtering may be different in different directions.

HTML

HTML stands for **Hyper Text Markup Language**. It is a formatting language used to define the appearance and contents of a web page. It allows us to organize text, graphics, audio, and video on a web page.

Key Points:

- The word Hypertext refers to the text which acts as a link.
- The word markup refers to the symbols that are used to define structure of the text. The markup symbols tells the browser how to display the text and are often called tags.
- The word Language refers to the syntax that is similar to any other language.

HTML was created by **Tim Berners-Lee** at **CERN**.

HTML Versions

The following table shows the various versions of HTML:

Version	Year
HTML 1.0	1991
HTML 2.0	1995
HTML 3.2	1997
HTML 4.0	1999
XHTML	2000
HTML5	2012

HTML Tags

Tag is a command that tells the web browser how to display the text, audio, graphics or video on a web page.

Key Points:

- Tags are indicated with pair of angle brackets.
- They start with a less than < character and end with a greater than > character.
- The tag name is specified between the angle brackets.
- Most of the tags usually occur in pair: the start tag and the closing tag.
- The start tag is simply the tag name is enclosed in angle bracket whereas the closing tag is specified including a forward slash /.
- Some tags are the empty i.e. they don't have the closing tag.
- Tags are not case sensitive.
- The starting and closing tag name must be the same. For example hello </i> is invalid as both are different.
- If you don't specify the angle brackets <> for a tag, the browser will treat the tag name as a simple text.
- The tag can also have attributes to provide additional information about the tag to the browser.

Basic tags

The following table shows the Basic HTML tags that define the basic web page:

Tag	Description
<html> </html>	Specifies the document as a web page.
<head> </head>	Specifies the descriptive information about the web documents.
<title> </title>	Specifies the title of the web page.
<body> </body>	Specifies the body of a web document.

The following code shows how to use basic tags.

```
<html>
  <head> Heading goes here...</head>
  <title> Title goes here...</title>
  <body> Body goes here...</body>
</html>
```

Formatting Tags

The following table shows the HTML tags used for formatting the text:

Tag	Description
 	Specifies the text as bold. Eg. this is bold text
 	It is a phrase text. It specifies the emphasized text. Eg. <i>Emphasized text</i>
 	It is a phrase tag. It specifies an important text. Eg. this is strong text
<i> </i>	The content of italic tag is displayed in italic. Eg. <i>Italic text</i>
	Specifies the subscripted text. Eg. X_1
	Defines the superscripted text. Eg. X^2
<ins> </ins>	Specifies the inserted text. Eg. The price of pen is now 2015 .
 	Specifies the deleted text. Eg. The price of pen is now 2015 .
<mark> </mark>	Specifies the marked text. Eg. It is raining

Table Tags

Following table describe the commonly used table tags:

Tag	Description
<table> </table>	Specifies a table.
<tr> </tr>	Specifies a row in the table.
<th> </th>	Specifies header cell in the table.
<td> </td>	Specifies the data in an cell of the table.
<caption> </caption>	Specifies the table caption.
<colgroup> </colgroup>	Specifies a group of columns in a table for formatting.

List tags

Following table describe the commonly used list tags:

Tag	Description
 	Specifies an unordered list.
 	Specifies an ordered list.
 	Specifies a list item.
<dl> </dl>	Specifies a description list.
<dt> </dt>	Specifies the term in a description list.
<dd> </dd>	Specifies description of term in a description list.

Frames

Frames help us to divide the browser's window into multiple rectangular regions. Each region contains separate html web page and each of them work independently.

A set of frames in the entire browser is known as frameset. It tells the browser how to divide browser window into frames and the web pages that each has to load.

The following table describes the various tags used for creating frames:

Tag	Description
<frameset> </frameset>	It is replacement of the <body> tag. It doesn't contain the tags that are normally used in <body> element; instead it contains the <frame> element used to add each frame.
<frame> </frame>	Specifies the content of different frames in a web page.
<base> </base>	It is used to set the default target frame in any page that contains links whose contents are displayed in another frame.

Forms

Forms are used to input the values. These values are sent to the server for processing. Forms uses input elements such as text fields, check boxes, radio buttons, lists, submit buttons etc. to enter the data into it.

The following table describes the commonly used tags while creating a form:

Tag	Description
<form> </form>	It is used to create HTML form.
<input> </input>	Specifies the input field.

`<textarea> </textarea>` Specifies a text area control that allows to enter multi-line text.
`<label> </label>` Specifies the label for an input element.

CSS

CSS is acronym of **Cascading Style Sheets**. It helps to define the presentation of HTML elements as a separate file known as CSS file having `.css` extension.

CSS helps to change formatting of any HTML element by just making changes at one place. All changes made would be reflected automatically to all of the web pages of the website in which that element appeared.

Embedding CSS into HTML

Following are the four methods to add CSS to HTML documents.

1. Inline Style Sheets
2. Embedded Style Sheets
3. External Style Sheets
4. Imported Style Sheets

Inline Style Sheets

Inline Style Sheets are included with HTML element i.e. they are placed inline with the element. To add inline CSS, we have to declare style attribute which can contain any CSS property.

Syntax:

```
<Tagname STYLE = " Declaration1 ; Declaration2 "> ... </Tagname>
```

Let's consider the following example using Inline Style Sheets:

```
<p style="color: blue; text-align: left; font-size: 15pt">  
Inline Style Sheets are included with HTML element i.e. they are placed  
inline with the element.  
To add inline CSS, we have to declare style attribute which can contain any  
CSS property.  
</p>
```

Embedded Style Sheets

Embedded Style Sheets are used to apply same appearance to all occurrence of a specific element. These are defined in element by using the `<style>` element.

The `<style>` element must include **type** attribute. The value of **type** attribute specifies what type of syntax it includes when rendered by the browser.

Syntax

```
<head> <title> .... </title>
<style type = "text/css">
.....CSS Rules/Styles....
</head>
```

Let's consider the following example using Embedded Style Sheets:

```
<style type="text/css">
p {color:green; text-align: left; font-size: 10pt}
h1 { color: red; font-weight: bold}
</style>
```

External Style Sheets

External Style Sheets are the separate **.css** files that contain the CSS rules. These files can be linked to any HTML documents using **<link>** tag with rel attribute.

Syntax:

```
<head> <link rel= "stylesheet"  type="text/css" href= "url of css file">
</head>
```

In order to create external css and link it to HTML document, follow the following steps:

- First of all create a CSS file and define all CSS rules for several HTML elements. Let's name this file as external.css.

```
p
{
  Color: orange;      text-align: left;      font-size: 10pt;
}
h1
{
  Color: orange;      font-weight: bold;
}
```

- Now create HTML document and name it as **externaldemo.html**.

```
<html>
<head>
<title> External Style Sheets Demo </title>
<link rel="stylesheet"  type="text/css" href="external.css">
</head>
<body>
<h1> External Style Sheets</h1>
<p>External Style Sheets are the separate .css files that contain the CSS
rules.</p>
</body>
</html>
```

Imported Style Sheets

Imported Style Sheets allow us to import style rules from other style sheets. To import CSS rules we have to use `@import` before all the rules in a style sheet.

Syntax:

```
<head><title> Title Information </title>
<style type="text/css">
@import URL (cssfilepath)
... CSS rules...
</style>
</head>
</style>
```

Let's consider the following example using Inline Style Sheets:

```
<html>
<head>
<title>External Style Sheets Demo </title>
<style>
@import url(external.css);
</style>
</head>
<body>
<h1> External Style Sheets</h1>
<p>External Style Sheets are the separate .css files that contain the CSS
rules.</p>
</body>
</html>
```

JavaScript

JavaScript is a lightweight, interpreted programming language with object-oriented capabilities that allows you to build interactivity into otherwise static HTML pages.

JavaScript code is not compiled but translated by the translator. This translator is embedded into the browser and is responsible for translating javascript code.

JavaScript is:

- Lightweight, interpreted programming language.
- Designed for creating network-centric applications.
- Complementary to and integrated with Java.
- Complementary to and integrated with HTML
- Open and cross-platform

JavaScript Statements

JavaScript statements are the commands to tell the browser to what action to perform. Statements are separated by semicolon ;.

JavaScript statement constitutes the JavaScript code which is translated by the browser line by line.

Example of JavaScript statement:

```
document.getElementById("demo").innerHTML = "Welcome";
```

Following table shows the various JavaScript Statements:

S.N.	Statement	Description
1.	switch case	A block of statements in which execution of code depends upon different cases. The interpreter checks each case against the value of the expression until a match is found. If nothing matches, a default condition will be used.
2.	If else	The if statement is the fundamental control statement that allows JavaScript to make decisions and execute statements conditionally.
3.	While	The purpose of a while loop is to execute a statement or code block repeatedly as long as expression is true. Once expression becomes false, the loop will be exited.
4.	do while	Block of statements that are executed at least once and continues to be executed while condition is true.
5.	for	Same as while but initialization, condition and increment/decrement is done in the same line.
6.	for in	This loop is used to loop through an object's properties.
7.	continue	The continue statement tells the interpreter to immediately start the next iteration of the loop and skip remaining code block.
8.	break	The break statement is used to exit a loop early, breaking out of the enclosing curly braces.
9.	function	A function is a group of reusable code which can be called anywhere in your programme. The keyword function is used to declare a function.
10.	return	Return statement is used to return a value from a function.
11.	var	Used to declare a variable.
12.	try	A block of statements on which error handling is implemented.
13.	catch	A block of statements that are executed when an error occur.
14.	throw	Used to throw an error.

JavaScript Comments

JavaScript supports both C-style and C++-style comments, thus:

- Any text between a // and the end of a line is treated as a comment and is ignored by JavaScript.
- Any text between the characters /* and */ is treated as a comment. This may span multiple lines.
- JavaScript also recognizes the HTML comment opening sequence <!--. JavaScript treats this as a single-line comment, just as it does the // comment.-->
- The HTML comment closing sequence --> is not recognized by JavaScript so it should be written as //-->.

Example:

```
<script language="javascript" type="text/javascript">
<!--

// this is a comment. It is similar to comments in C++

/*
 * This is a multiline comment in JavaScript
 * It is very similar to comments in C Programming
 */
//-->
</script>
```

JavaScript variable

Variables are referred as named containers for storing information. We can place data into these containers and then refer to the data simply by naming the container.

Rules to declare variable in JavaScript

- In JavaScript variable names are case sensitive i.e. a is different from A.
- Variable name can only be started with an underscore _ or a letter *from a to z or A to Z*, or dollar \$ sign.
- Numbers 0 to 9 can only be used after a letter.
- No other special character is allowed in variable name.

Before you use a variable in a JavaScript program, you must declare it. Variables are declared with the var keyword as follows:

```
<script type="text/javascript">
<!--
var money;
var name, age;
//-->
</script>
```

Variables can be initialized at time of declaration or after declaration as follows:

```
<script type="text/javascript">
```

```
<!--  
var name = "Ali";  
var money;  
money = 2000.50;  
//-->  
</script>
```

Javascript Data Type

There are two kinds of data types as mentioned below:

- Primitive Data Type
- Non Primitive Data Type

Primitive Data Types are shown in the following table:

S.N.	Datatype Description
	String
1.	Can contain groups of character as single value. It is represented in double quotes. E.g. var x= "tutorial".
	Numbers
2.	Contains the numbers with or without decimal. E.g. var x=44, y=44.56;
	Booleans
3.	Contain only two values either true or false. E.g. var x=true, y= false.
	Undefined
4.	Variable with no value is called Undefined. E.g. var x;
	Null
5.	If we assign null to a variable, it becomes empty. E.g. var x=null;

Following table contains Non primitive Data Types:

S.N.	Datatype Description
	Array
1.	Can contain groups of values of same type. E.g. var x={1,2,3,55};
	Objects
2.	Objects are stored in property and value pair. E.g. var rectangle = { length: 5, breadth: 3};

JavaScript Functions

Function is a group of reusable statements *Code* that can be called any where in a program. In javascript function keyword is used to declare or define a function.

Key Points:

- To define a function use function keyword followed by functionname, followed by parentheses .
- In parenthesis, we define parameters or attributes.
- The group of reusable statements *code* is enclosed in curly braces {}. This code is executed whenever function is called.

Syntax:

```
function functionname (p1, p2) {
  function coding...
}
```

JavaScript Operators

Operators are used to perform operation on one, two or more operands. Operator is represented by a symbol such as +, =, *, % etc. Following are the operators supported by javascript:

- Arithmetic Operators
- Comparison Operators
- Logical *or* Relational Operators
- Assignment Operators
- Conditional *or* ternary Operators
- Arithmetic Operators

Control Structure

Control structure actually controls the flow of execution of a program. Following are the several control structure supported by javascript.

1. if ... else
2. switch case
3. do while loop
4. while loop
5. for loop

PHP

PHP is acronym of Hypertext Preprocessor *PHP* is a programming language that allows web developers to create dynamic content that interacts with databases. PHP is basically used for developing web based software applications.

PHP started out as a small open source project that evolved as more and more people found out how useful it was. Rasmus Lerdorf unleashed the first version of PHP way back in 1994.

Key Points

- **PHP is a recursive acronym for "PHP: Hypertext Preprocessor".**
- **PHP is a server side scripting language that is embedded in HTML. It is used to manage dynamic content, databases, session tracking, even build entire e-commerce sites.**
- **It is integrated with a number of popular databases, including MySQL, PostgreSQL, Oracle, Sybase, Informix, and Microsoft SQL Server.**
- **PHP is pleasingly zippy in its execution, especially when compiled as an Apache module on the Unix side. The MySQL server, once started, executes even very complex queries with huge result sets in record-setting time.**
- **PHP supports a large number of major protocols such as POP3, IMAP, and LDAP. PHP4 added support for Java and distributed object architectures *COMandCORBA*, making n-tier development a possibility for the first time.**

Uses of PHP

- **PHP performs system functions, i.e. from files on a system it can create, open, read, write, and close them.**
- **PHP can handle forms, i.e. gather data from files, save data to a file, through email you can send data, return data to the user.**
- **You add, delete, modify elements within your database through PHP.**

- Access cookies variables and set cookies.
- Using PHP, you can restrict users to access some pages of your website.
- It can encrypt data.

Characteristics

Five important characteristics make PHP's practical nature possible:

- Simplicity
- Efficiency
- Security
- Flexibility
- Familiarity

"Hello World" Script in PHP:

To get a feel for PHP, first start with simple PHP scripts. Since "Hello, World!" is an essential example, first we will create a friendly little "Hello, World!" script.

As mentioned earlier, PHP is embedded in HTML. That means that in amongst your normal HTML *or XHTML if you're cutting-edge* you'll have PHP statements like this:

```
<html>
<head>
<title>Hello World</title>
<body>
  <?php echo "Hello, World!";?>
</body>
</html>
```

It will produce following result:

Hello, World!

If you examine the HTML output of the above example, you'll notice that the PHP code is not present in the file sent from the server to your Web browser. All of the PHP present in the Web page is processed and stripped from the page; the only thing returned to the client from the Web server is pure HTML output.

All PHP code must be included inside one of the three special markup tags that are recognised by the PHP Parser.

```
<?php PHP code goes here ?>
<? PHP code goes here ?>
<script language="php"> PHP code goes here </script>
```